

Top 40 Requirements You Should Know: 2021 IECC

6/13/2023



SEDAC
SMART ENERGY DESIGN ASSISTANCE CENTER

Providing effective energy strategies for buildings and communities

Schedule

8:30 – 9:00 am: Registration

9:00 – 10:20 am: Session A

- Commercial Definitions
- Commercial Envelope
- Commercial HVAC

10:20 am – 10:40 am: Break

10:40 am – Noon: Session B

- Commercial Lighting
- Residential Definitions
- Residential
- Residential Performance

SEDAC is a Preferred Education Provider with the International Code Council (ICC). Credits earned on completion of this program will be reported to ICC for ICC members. Certificates of Completion will be issued to all participants.



This workshop is approved for 3 LU/HSW CES credits from the American Institute of Architects (AIA). Credits earned on completion will be reported for AIA members.



Learning Objectives

1. Describe the changes in the updated Illinois Energy Conservation Code (2018 IECC to 2021 IECC)
2. Summarize the most significant Illinois Energy Conservation Code compliance issues in the commercial and residential provisions
3. Comply with the updated Illinois Energy Conservation Code for commercial and residential building design and construction
4. Compare the proposed Illinois Amendments to the 2021 IECC and evaluate their impact on the code

Who We Are

We assist buildings and communities in achieving energy efficiency, saving money, and becoming more sustainable.

We are an applied research program at the University of Illinois.

Our mission: Reduce the energy footprint of Illinois and beyond.

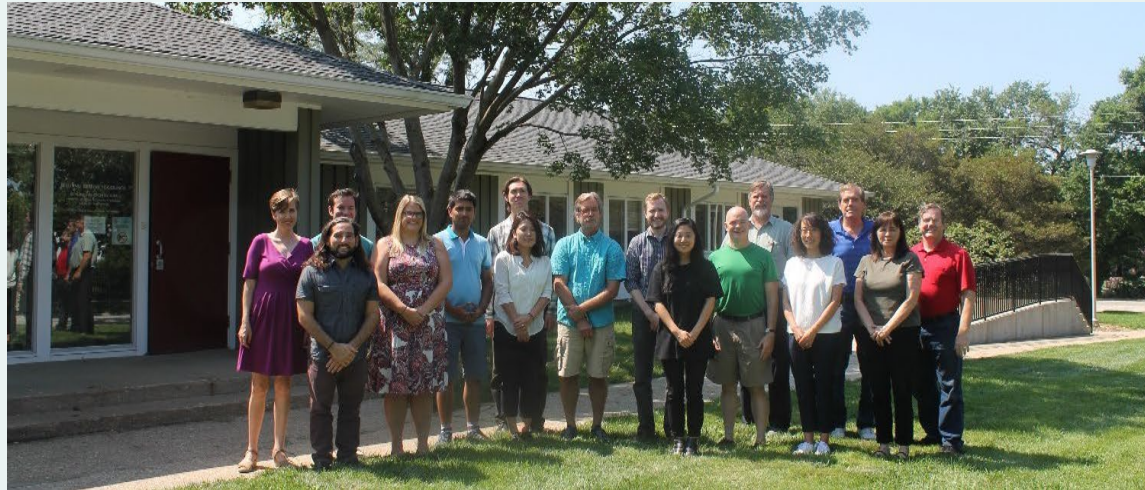

What We Do

We **help facilities** become more energy efficient.

We **educate**.

We **research**.

We **advocate** for a greener future.



SEDAC is the Illinois Energy Conservation Code Training Provider



This training program is sponsored by **Illinois State Energy Office**

Energy Code Training Program

- Technical support
energycode@illinois.edu
800.214.7954
- Online resources at
smartenergy.illinois.edu/energy-code
- Workshops
- Webinars
- Online on-demand training modules



Illinois Energy Conservation Code



[About](#) ▾ [Programs](#) ▾ [Who We Serve](#) ▾ [Resources](#) ▾ [Blog](#) [Contact](#)



Illinois Energy Conservation Code

[Home](#) > [Energy Code Training](#) > [Illinois Energy Conservation Code](#)

Click [here](#) for the 2022 Chicago Energy Transformation Code.

Updated Illinois Energy Conservation Code (2021 IECC with IL Amendments) is expected to be effective in 2023

The updated Illinois Energy Conservation Code, based on the 2021 IECC with Illinois Amendments, is expected to become effective **in 2023** (tentative).

The separate documents can be accessed here:

- [2021 IECC](#)
- Illinois Amendments are not yet available



CDB.BuildingCodes@Illinois.gov

TRAINING & SUPPORT SERVICES



Workshops



Webinars



Online courses



Technical support

ENERGY CODE RESOURCES



Illinois Energy Conservation Code



Chicago Energy Transformation Code



Illinois Stretch Code



Frequently asked questions



Checklists



Energy code smart tips

Access to 2021 IECC, IL Amendments & Chicago Energy Code

<https://codes.iccsafe.org/content/IECC2021P2>

1st DRAFT:

CDB May 2023 Board Book pp 029-069

<https://codes.iccsafe.org/codes/illinois/Chicago>

Menu  Search all of Digital Codes

All Codes <

Legend Information

CODE SECTIONS MY NOTES

2021 INTERNATIONAL ENERGY CONSERVATION CODE (IECC)

COPYRIGHT

PREFACE

ARRANGEMENT AND FORMAT OF THE 2021 IECC

ABBREVIATIONS AND NOTATIONS

IECC—COMMERCIAL PROVISIONS

CHAPTER 1 [CE] SCOPE AND ADMINISTRATION

CHAPTER 2 [CE] DEFINITIONS

CHAPTER 3 [CE] GENERAL REQUIREMENTS

CHAPTER 4 [CE] COMMERCIAL ENERGY EFFICIENCY





2021 International (IECC)

♥ Add to Favorites

The 2021 IECC® addresses energy efficiency on several resources and the impact of energy usage on the environment.

Related Titles

 **2021 Complete Revision History to the 2021 I-Codes - IECC: Successful Changes and Public Comments** >

 **2021 Significant Changes to the International Energy Conservation Code** >

CHAPTER 1 [CE] SCOPE AND ADMINISTRATION

SECTION C101 SCOPE AND GENERAL REQUIREMENTS

C101.1 Title. This code shall be known as the *International Energy Conservation Code of [NAME OF JURISDICTION]* and shall be cited as such. *Illinois Energy Conservation Code* or "this Code" and shall mean:

With respect to the State facilities covered by 71 Ill. Adm. Code 600.Subpart B:

This Part, all additional requirements incorporated within Subpart B (including the 2018 International Energy Conservation Code, including all published errata but excluding published supplements that encompass ASHRAE 90.1-2016), and any statutorily authorized adaptations to the incorporated standards adopted by CDB are effective July 1, 2019.

With respect to the privately funded commercial facilities covered by 71 Ill. Adm. Code 600.Subpart C:

This Part, all additional requirements incorporated within Subpart C (including the 2018 International Energy Conservation Code, including all published errata and excluding published supplements that encompass ASHRAE 90.1-2016), and any statutorily authorized adaptations to the incorporated standards adopted by CDB, are effective July 1, 2019.

C101.1.2 Adoption. The Board shall adopt

C101.1.3 Adaptation. The Board may appropriately adapt the International Energy Conservation Code to apply to the particular economy, population, distribution, geography and climate of the State and construction within the State, consistent with the public policy objectives of the EEB Act.

C101.5 Compliance. Residential buildings shall meet the provisions of IECC Residential Provisions. Commercial buildings shall meet the provisions of IECC Commercial Provisions the Illinois Energy Conservation Code covered by 71 Ill. Adm. Code 600.Subpart C. The local authority having jurisdiction (AHJ) shall establish its own procedures for enforcement of the Illinois Energy Conservation Code. Minimum compliance shall be demonstrated by submission of:

1. Compliance forms published in the ASHRAE 90.1 User's Manual; or
2. Compliance Certificates generated by the U.S. Department of Energy's COMcheck™ Code compliance tool; or
3. Other comparable compliance materials that meet or exceed, as determined by the AHJ, the compliance forms published in the ASHRAE 90.1 User's Manual or the U.S. Department of Energy's COMcheck™ Code compliance tool; or
4. The seal of the architect/engineer as required by Section 14 of the Illinois Architectural Practice Act [225 ILCS 305], Section 12 of the Structural Engineering Licensing Act [225 ILCS 340] and Section 14 of the Illinois Professional Engineering Practice Act [225 ILCS 325].

ARTICLE XIII. CHICAGO ENERGY CONSERVATION CODE

SECTION 1. The Municipal Code of Chicago is hereby amended by inserting a new Title 14N, as follows:

TITLE 14N ENERGY CONSERVATION CODE

PART I – COMMERCIAL PROVISIONS

CHAPTER 14N-C1 SCOPE AND PURPOSE

14N-C1-C001 Adoption of the commercial provisions of the International Energy Conservation Code by reference.

The commercial provisions of the *International Energy Conservation Code*, 2018 edition, second printing, and all erratum thereto identified by the publisher (hereinafter referred to as "IECC-CE"), except Appendix CA, are adopted by reference and shall be considered part of the requirements of this title except as modified by the specific provisions of this title.

If a conflict exists between a provision modified by this title and a provision adopted without modification, the modified provision shall control.

14N-C1-C002 Citations.

Provisions of IECC-CE which are incorporated into this title by reference may be cited as follows:

14N-C[IECC-CE chapter number]-[IECC-CE section number]

14N-C1-C003 Global modifications.

The following modifications shall apply to each provision of IECC-CE incorporated into this title:

- Replace each occurrence of "International Codes" with "Chicago Construction Codes."
- Replace each occurrence of "International Building Code" with "Chicago Building Code."
- Replace each occurrence of "ASME A17.1" or "ASME A17.1/CSA B44" with "the Chicago Conveyance Device Code."
- Replace each occurrence of "NFPA 70" with "the Chicago Electrical Code."

SEDAC Top 40 & Other Workshops

Top 40 Requirements You Should Know: 2021 IECC

- Jun 13, 2023 (DuPage County)

Other workshops

- Archived: Importance of Mechanical Insulation: Safety & Efficiency

Registration: <https://smartenergy.illinois.edu/events>

SEDAC Top 10 Series Webinars

Top 10 Requirements You Should Know: 2021 IECC

- Residential: Archived
- Commercial Envelope: Archived
- Commercial Lighting: Archived
- Commercial HVAC: Archived

Registration: <https://smartenergy.illinois.edu/events>

Commercial Definitions

- Equipment Building: ≥ 7 watts/SF
- Computer Room: ≤ 20 watts/SF or ≤ 10 kW ITE load total
- Data Center > 20 watts/SF and 10 kW ITE load total (Uses ASHRAE 90.4)

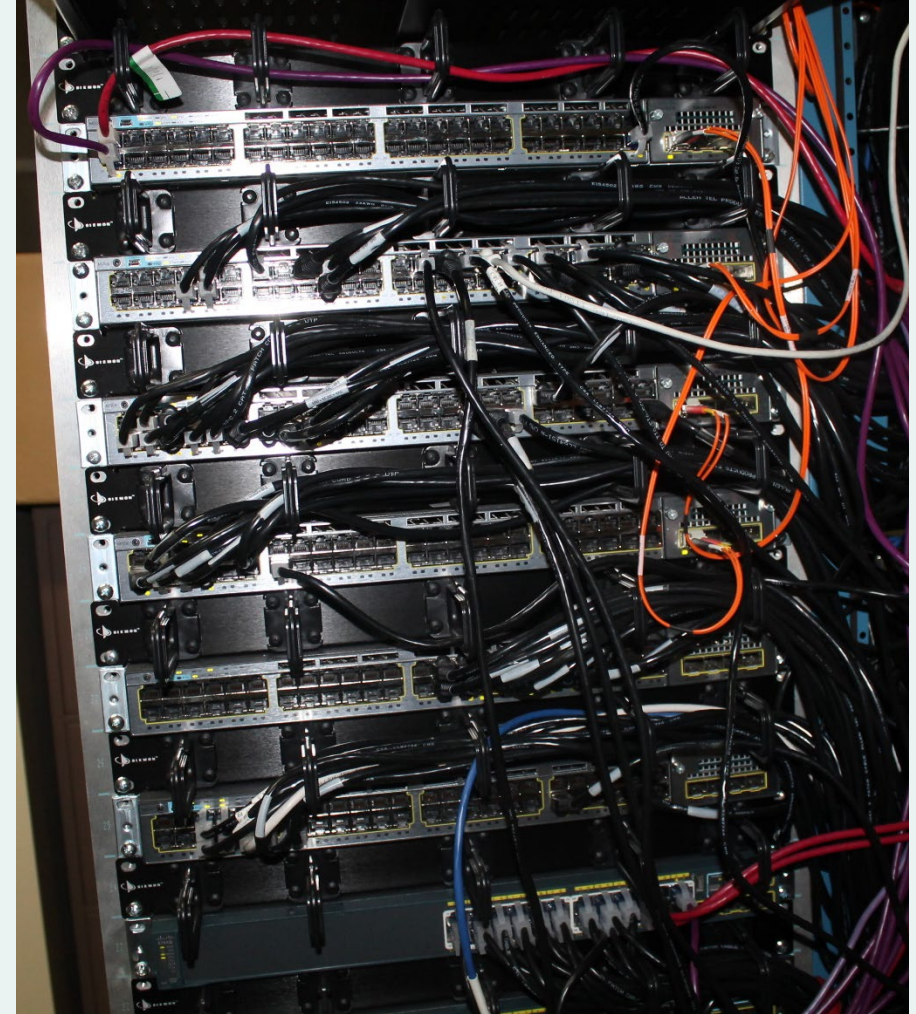

Climate Zones

- Counties with adjusted climate zones (5A to 4A)
 - Calhoun
 - Clark
 - Coles
 - Cumberland
 - Greene
 - Jersey



Commercial Envelope

Building Exemptions from Illinois Energy Code

- Exempt from locally adopted building code
- Don't contain conditioned space
- Buildings without comfort conditioning
- Listed historic buildings
- Buildings specified in IECC



Image source: <https://www2.illinois.gov/sites/agr/Pages/default.aspx>

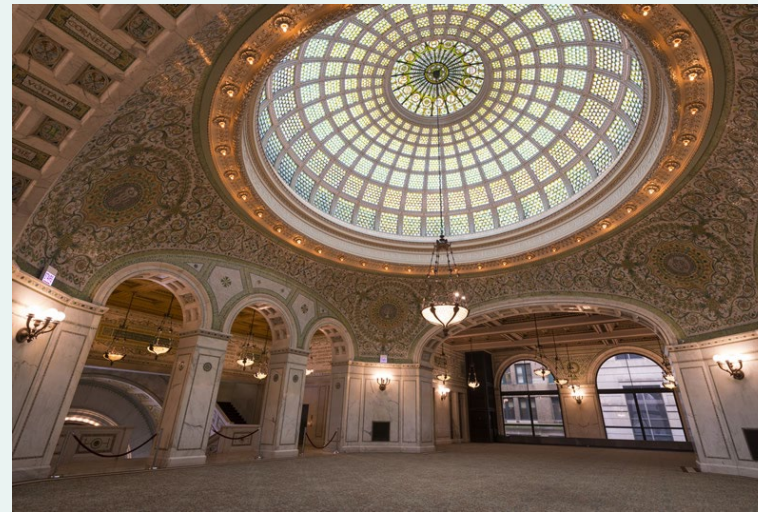

Certificate Requirements

Commercial Thermal Envelope Certificate

Name of Designer/Builder: _____ Location (address): _____
 Energy Code Edition: _____
 2021 IECC: Yes No Permit Date: _____
 ASHRAE 90.1-2019 Yes No Permit #: _____
 Other (please indicate): _____ Building Area (sf): _____

1. Insulation Rating

Designation	R-Value (per assembly)	% (of component)	R-Value (area-weighted average)
Ceiling/Roof			
Walls (Above Grade)			
(Above Grade)			
(Below Grade)			
(Below Grade)			
Floors/Slabs			
Ducts (Unconditioned space)			
(Outdoor ducts)			

2. Fenestration Rating

Designation	NFRC U-Factor (per assembly)	NFRC SHGC (of component)	% (of component)	NFRC U-Factor (area-weighted average)	NFRC SHGC (area-weighted average)
Window					
Opaque door					
Skylight					

3. Air Leakage Test Results

Blower door _____ cfm/sf/ 75 Pa. Test date: _____ Tested by: _____

- R-values of insulation for: roofs, walls, foundations and slabs, basement walls, crawlspace walls and floors, and ducts outside conditioned space
- U-factors and SHGC of fenestration
- Results from building envelope air leakage testing

Compliance Resources



Energy Code Checklists

Check out our checklists to help with energy code site inspection and compliance!

2021 IECC: Yes No Permit Date: _____
ASHRAE 90.1-2019: Yes No Permit #: _____
Other (please indicate): _____ Building Area (sf): _____

1. Insulation Rating

Designation	R-Value (per assembly)	% (if composite)	R-Value (per weighted section)
Ceiling/Roof			
Walls (Above Grade)			
Walls (Below Grade)			
Floors/Slabs			
Ducts (Unconditioned space)			
Ducts (Conditioned space)			

2. Fenestration Rating

Designation	NFRC U-Factor (per assembly)	NFRC SHGC (if composite)	NFRC U-Factor (per weighted section)	NFRC SHGC
Window				
Opaque door				

Commercial Thermal Envelope Certificate

🕒 September 8, 2022

2021 IECC requires all new commercial buildings to complete and post a permanent Thermal Envelope Certificate. This certificate template can [...]

1. Insulation Rating

	R-Value	R-Value
Ceiling/Roof	Attic: _____	Vaulted: _____
Walls	Frame: _____	Mass: _____
Floors	Basement: _____	Crawl space: _____
Ducts	Over unconditioned space: _____	Slab edge: _____
	Attic: _____	Other: _____

2. Fenestration Rating

	NFRC U-Factor	NFRC SHGC
Window	_____	_____
Opaque door	_____	_____
Skylight	_____	_____

3. Air Leakage Test Results

Blower door: _____ ACH/50 Pa. Duct testing: _____ Cfm/100 ft²

4. Equipment Performance

	Type	Size	Efficiency
Heating system	_____	_____	_____
Cooling system	_____	_____	_____
Water heater	_____	_____	_____

Indicate if the following have been installed:

Electric furnace Gas-fired unvented room heater Baseboard electric heater

5. Photovoltaic Panel Systems

Area covered: _____ Panel kW: _____

Illinois Home Energy Code Checklist & Energy Certificate

🕒 June 16, 2022

For Homeowners and Realtors. Are you interested in buying an energy efficient home? Do you want to learn how to make your home more energy efficient? This checklist can help you quickly assess a home's energy performance and construction.

Greenhouses

- Opaque envelope complying with C402.2 and C402.4.5
- Internal partitions between greenhouse and other conditioned space complying with C402.2, C402.4.3 and C402.4.5
- Fenestration in compliance with Table C402.1.1.1



Equipment Buildings

- Floor area not more than **1,200 sf**
- House electric equipment not less than 7 watts per square foot and not intended for human occupancy
- Heating system capacity not greater than 17,000 Btu/hr w/ setpoint restricted to 50F or less
- Average wall and roof U-factor of less than 0.200 in CZ 1-5

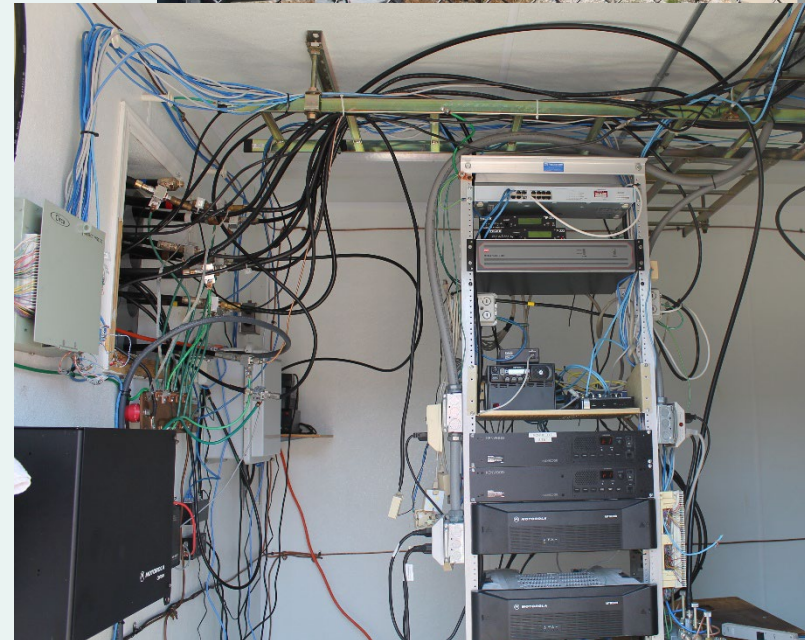

Table
C402.1.3

Excerpts: Insulation Component Min. R-Values

Climate Zone & Group	Roofs			Walls				
	Above Deck	Metal Building	Attic/ Other	Mass	Metal Building	Metal Framed	Wood Framed	Below Grade
CZ 4 Other	R-30 ci	R-19 + R-11 LS	R-49 (R-30)	R-9.5ci	R-13 + R-13ci	R-13 + R-7.5ci	R-13 + R-3.8ci or R-20	R-7.5 ci
CZ 4 Group R	R-30 ci	R-19 + R-11 LS	R-49 (R-30)	R-11.4ci	R-13 + R-14ci (+R-13ci)	R-13 + R-7.5ci	R-13 + R-3.8ci or R-20	R-10ci (R-7.5ci)
CZ 5 Other	R-30 ci	R-19 + R-11 LS	R-49 (R-30)	R-11.4ci	R-13 + R-14ci (+R-13ci)	R-13 + R-10ci (+R-7.5ci)	R-13 + R-7.5ci or R-20 + R-3.8ci (R-13 + R-3.8ci or R-20)	R-7.5 ci
CZ 5 Group R	R-30 ci	R-19 + R-11 LS	R-49	R-13.3ci	R-13 + R-14ci (+R-13ci)	R-13 + R-10ci (+R-7.5ci)	R-13 + R-7.5ci or R-20 + R-3.8ci	R-10 ci (R-7.5ci)

Values are 2021 IECC requirements.

Original 2018 IECC values in white text (R-value)

Table
C402.1.3

Excerpts: Insulation Component Min. R-Values

Climate Zone & Group	Floors			
	Mass	Joist /Framed	Unheated Slab	Heated Slab*
4 Other	R-14.6ci (R-10ci)	R-30	R-15 24" below (R-10 24")	R-15 24" below grade + R-5 under
4 Group R	R-16.7ci (R-10.4ci)	R-30	R-15 24" below (R-10 24")	R-15 24" below grade + R-5 under
5 Other	R-14.6ci (R-10ci)	R-30	R-15 24" below (R-10 24")	R-15 36" below grade + R-5 under
5 Group R	R-16.7ci (R-12.5ci)	R-30	R-20 24" below (R-10 24")	R-15 36" below grade + R-5 under

*Note that for heated slab-on-grade construction, insulation is permitted to stop at the bottom of the slab edge

Requirements for doors in the 2018 R-value table have been moved to the U-factor table in 2021 IECC

Table
C402.1.4

Excerpts: Insulation Component Max. U-Factors

Climate Zone & Group	Roofs			Walls				
	Above Deck	Metal Building	Attic/ Other	Mass	Metal Building	Metal Framed	Wood Framed	Below Grade
CZ 4 Other	U-0.032	U-0.035	U-0.021 (U-0.027)	U-0.104	U-0.052	U-0.064	U-0.064	C-0.119
CZ 4 Group R	U-0.032	U-0.035	U-0.021 (U-0.027)	U-0.090	U-0.050 (U-0.052)	U-0.064	U-0.064	C-0.092 (C-0.119)
CZ 5 Other	U-0.032	U-0.035	U-0.021 (U-0.027)	U-0.090	U-0.050 (U-0.052)	U-0.055 (U-0.064)	U-0.051 (U-0.064)	C-0.119
CZ 5 Group R	U-0.032	U-0.035	U-0.021	U-0.080	U-0.050 (U-0.052)	U-0.055 (U-0.064)	U-0.051 (U-0.064)	C-0.092 (C-0.119)

Values are 2021 IECC requirements.

Original 2018 IECC values in white text (U-factor)

Table
C402.1.4

Excerpts: Insulation Component Max. U-Factors

Climate Zone & Group	Floors				Doors		
	Mass	Joist /Framed	Unheated Slab	Heated Slab*	Non-Swinging**	Swinging	Garage <14% Glazing
4 Other	U-0.057 (U-0.076)	U-0.033	F-0.52 (F-0.54)	F-0.62 (F-0.86 + 0.64)	U-0.31 (R-4.75)	U-0.37 (U-0.61)	U-0.31
4 Group R	U-0.051 (U-0.074)	U-0.033	F-0.52 (F-0.54)	F-0.62 (F-0.86 + 0.64)	U-0.31 (R-4.75)	U-0.37 (U-0.61)	U-0.31
5 Other	U-0.057 (U-0.074)	U-0.033	F-0.52 (F-0.54)	F-0.62 (F-0.79 + 0.64)	U-0.31 (R-4.75)	U-0.37 (U-0.61)	U-0.31
5 Group R	U-0.051 (U-0.064)	U-0.033	F-0.51 (F-0.54)	F-0.62 (F-0.79 + 0.64)	U-0.31 (R-4.75)	U-0.37 (U-0.61)	U-0.31

*Corrected 2018 IECC heated slab F-factor listings to match ASHRAE 90.1 Appendix A – not actual heated slab improvement

**Non-swinging doors in the 2018 R-value table have been moved to the U-factor table in 2021 IECC, and requirement relaxed

Opaque/Non-swinging Door Requirements

- Opaque Doors (swinging or non-swinging w/ <50% glazing) shall comply with Table C402.1.4 and be considered as part of the gross area of above-grade walls [C402.5.1]
- Opaque Non-swinging Doors
 - Horizontally hinged sectional doors with a single row of fenestration ($14\% > \text{Fenestration Area} < 25\%$ of total door area)
 - U-Factor < 0.44 CZ 0-6
 - Other doors shall comply with C402.4.3 U-Factor and SHGC requirements



Tapered Roof Assembly

- Average R-value can be used for tapered deck insulation [C402.2.1.1]
- Min. thickness shall be 1" [C402.2.1.2]
- Min. of 2 staggered layers except at gutter edge, drain, or scupper [C402.2.1.4]
- C402.1.4.1.1 sets comparable requirements for U-factor compliance

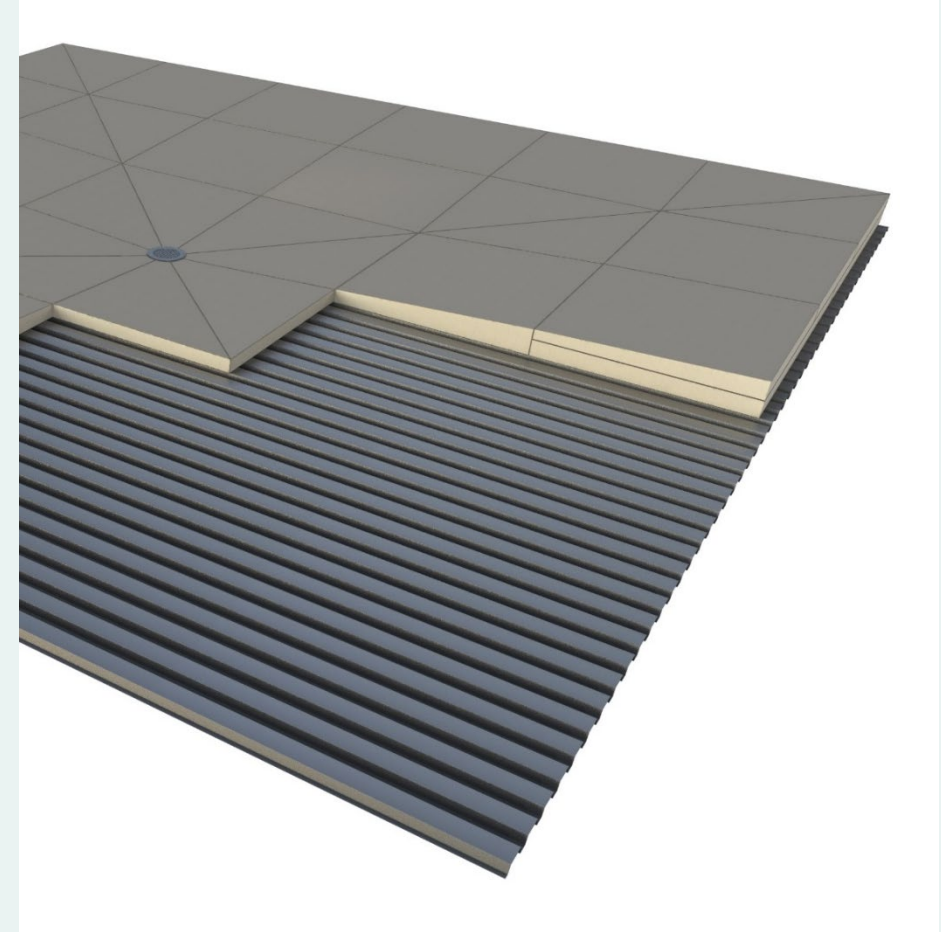

Image courtesy of PIMA

Perimeter Insulation

- Clarifies that where the slab on grade is greater than 24 inches below the finished exterior grade, perimeter insulation is not required.

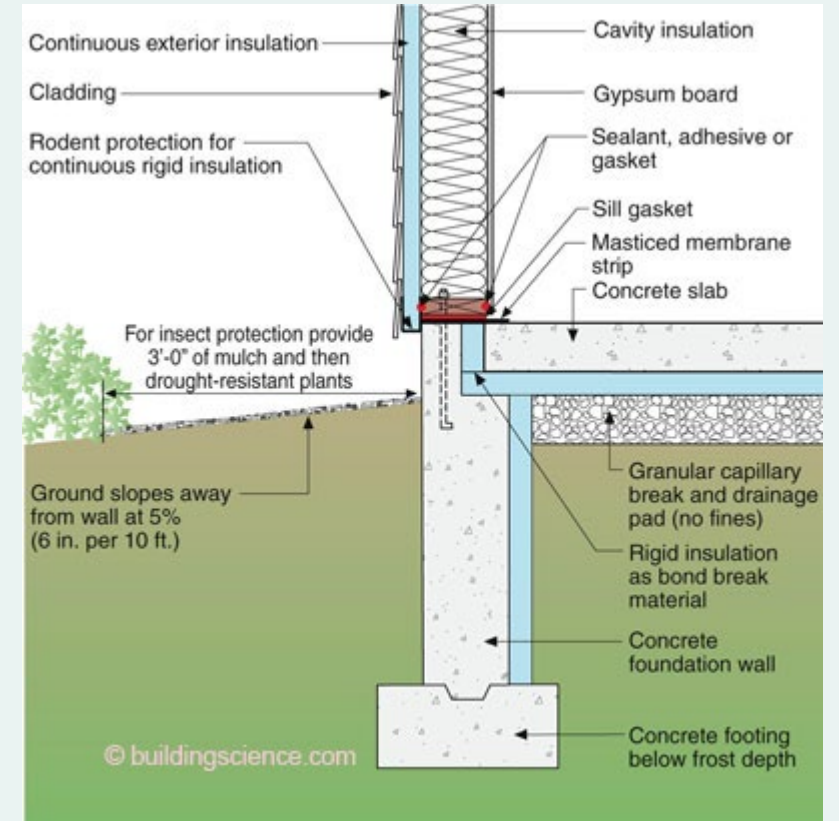

Image courtesy of buildingscience.com

Skylight Minimum Exception

- Excludes spaces designated as storm shelters designed in accordance with ICC 500

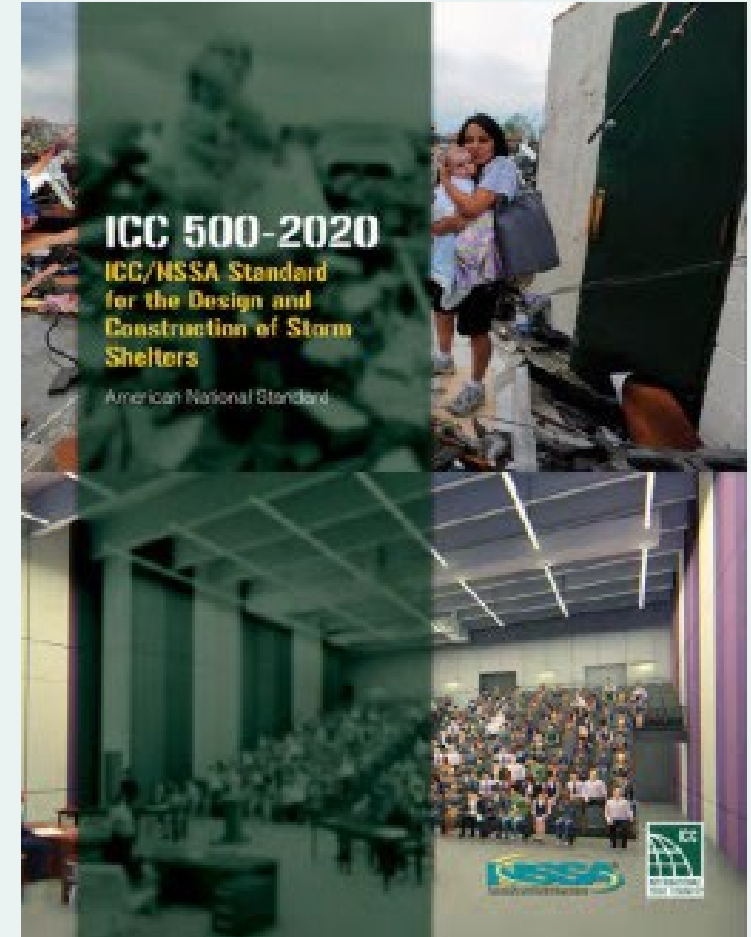

Image courtesy of ICC

Table
C402.4

Fenestration Max. U-Factor & SHGC Requirements

2018 IECC

CLIMATE ZONE	4 EXCEPT MARINE	5 AND MARINE 4		
Vertical Fenestration				
U-Factors				
Fixed fenestration	0.38	0.38		
Operable fenestration	0.45	0.45		
Entrance doors	0.77	0.77		
SHGC				
Orientation ^a	SEW	N	SEW	N
PF < 0.2	0.36	0.48	0.38	0.51
0.2 ≤ PF < 0.5	0.43	0.53	0.46	0.56
PF ≥ 0.5	0.58	0.58	0.61	0.61
Skylights				
U-factor	0.50	0.50		
SHGC	0.40	0.40		

2021 IECC

CLIMATE ZONE	4 EXCEPT MARINE	5 AND MARINE 4		
Vertical Fenestration				
U-Factors				
Fixed fenestration	0.36	0.36		
Operable fenestration	0.45	0.45		
Entrance doors	0.63	0.63		
SHGC				
	Fixed	Operable	Fixed	Operable
PF < 0.2	0.36	0.33	0.38	0.33
0.2 ≤ PF < 0.5	0.43	0.40	0.46	0.40
PF ≥ 0.5	0.58	0.53	0.61	0.53
Skylights				
U-factor	0.50	0.50		
SHGC	0.40	0.40		



Buildings with more east/west fenestration than north/south fenestration have increased performance criteria depending on the ratio

$$A_w * SHGC_w \leq (A_t * SHGC_c) / 5$$

And

$$A_e * SHGC_e \leq (A_t * SHGC_c) / 5$$

Area west/east/total

SHGC west/east/code table

C402.4 value



Minimum Skylight Area

Same required toplit areas as 2018, but determination updated:

1. VT not less than 0.40 **OR** VT_{annual} **not less than 0.26**
2. Effective aperture:
 1. 1% using VT for standard skylights
 2. **0.66% using Tubular Daylight VT_{annual}**

Update accounts for differences in traditional vs tubular daylight systems

Similar minor updates made throughout C402.4 to account for tubular daylight devices

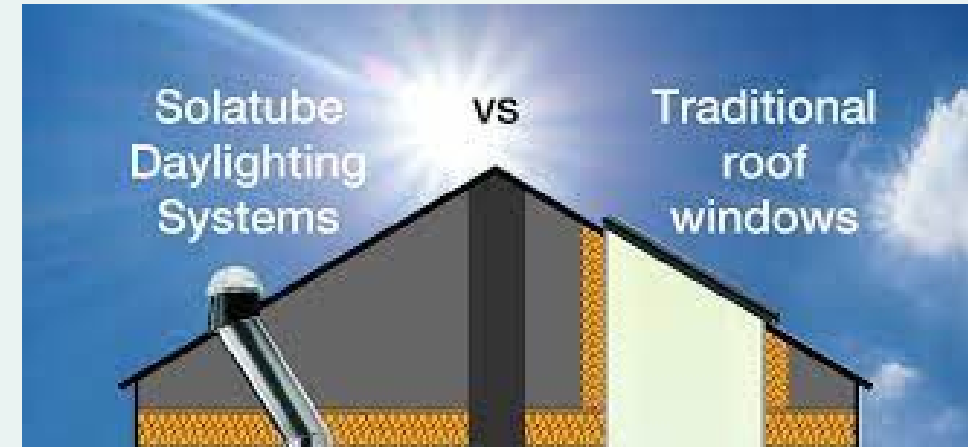

Image source: <https://www.solatubesouth.co.uk/solatube-vs-roof-windows/>

Summary of Air Barrier Requirements

- Air barrier materials must be installed inside, outside, or part of envelope assembly [C402.5.1]
 - Note: No AND. Either interior OR exterior, allows for drying
- Minimizing air leakage through fenestration [C402.5.4]
- Minimize air leakage through purposeful openings/penetrations [C402.5.5 thru .5.11]

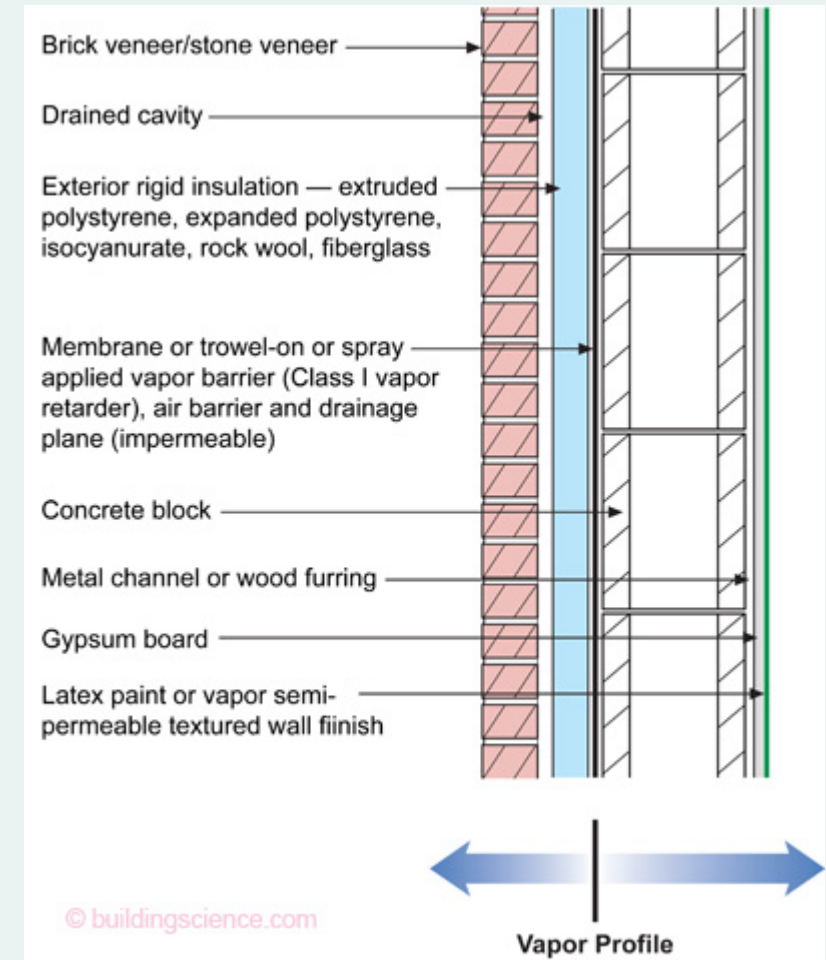

Image source:

https://www.buildingscience.com/sites/default/files/migrate/jpg/Masonry_Figure_06.jpg

Air Barrier Compliance

- Buildings or spaces including Group R & I occupancies shall meet C402.5.2:
Dwelling & sleeping unit enclosure testing [C402.5.2]
- Buildings or spaces other than Group R & I occupancies shall meet C402.5.3:
Building thermal envelope testing [C402.5.3]
- No exceptions for Climate Zones 4A or 5A

**ALL NEW COMMERCIAL BUILDINGS
IN IL MUST BE PRESSURE TESTED**

NEW!



Air barrier installation verified by code official, registered design professional, or approved agency per:

- **Review of construction documents** & other supporting data
- **Inspection** of continuous air barrier components and & assemblies during construction while air barrier still accessible for inspection and repair
- **Final commissioning** report provided for inspections completed by registered design professional or approved agency
 - To building owner or owner's authorized agent and code official
 - Report to identify deficiencies found during review of construction documents and inspection and details of corrective measures taken

Dwelling & Sleeping Unit Enclosure Testing

- Measured air leakage not to exceed 0.30 cfm/sf of testing unit enclosure area @ 0.2 inch water gauge (50 Pa)
- For multiple dwelling units in single thermal envelope, test individually, and building leakage to be unit envelope area weighted average of leakage rates.
- Units tested separately with unguarded blower door test
 - Buildings w/ **fewer than 8** testing units, **test all units**
 - Buildings w/ **8 or more** testing units, the **greater of 7 units or 20% of units** shall be tested
 - Sample to include a top floor, ground floor, and unit with the largest enclosure area).
 - Each unit not in compliance requires 2 additional units to be tested

Building Thermal Envelope Testing

- Measured air leakage not to exceed 0.40 cfm/sf of thermal envelope area @ 0.3 inch water gauge (75 Pa) for whole building test.
- Alternative sampling approach for larger buildings:
 - Area-weighted average can't exceed the whole building air leakage limit
 - Required testing samples:
 - Entire envelope area of spaces directly under a roof
 - Entire envelope area of spaces with building entrance, exposed floor, loading dock, or below grade
 - 25% or more representative sample of remaining thermal envelope
- If total leakage between 0.40 cfm/sf and 0.60 cfm/sf, allowed to complete diagnostic testing and non-destructive remediation without additional testing.
 - Must submit report of corrective actions

Operable Openings Interlock

- Conditioned space with a door opening >40 sq ft to the outdoors shall be provided with controls that change HVAC settings when door is opened:
- Disable heating or lower setpoint to 55 F (or lower)
- Disable cooling or raise setpoint to 90 F (or higher)
- within 10 min of door opening



Photo Courtesy of Control By Web



Photo Courtesy of Teutopolis Event Center

Additional Efficiency Requirements

SECTION
C406.2.1: 5% heating efficiency improvement
C406.2.2: 5% cooling efficiency improvement
C406.2.3: 10% heating efficiency improvement
C406.2.4: 10% cooling efficiency improvement
C406.3: Reduced lighting power
C406.4: Enhanced digital lighting controls
C406.5: On-site renewable energy
C406.6: Dedicated outdoor air
C406.7.2: Recovered or renewable water heating
C406.7.3: Efficient fossil fuel water heater
C406.7.4: Heat pump water heater
C406.8: Enhanced envelope performance
C406.9: Reduced air infiltration
C406.10: Energy monitoring
C406.11: Fault detection and diagnostics system

- Formerly (2018), choose 1 measure
- Now (2021), **collect 10 points**
(~2.5% savings)
 - Point Value Tables based on Occupancy Group

IL Amendment added:

- Grid Integrated HVAC controls
- Grid integrated water heating controls



- Automatically **increasing** zone cooling setpoint
 - by a **minimum of 4°F**
- Automatically **decreasing** zone heating setpoint
 - by a **minimum of 4°F**
- Automatically **decreasing** zone cooling setpoint
 - by a **minimum of 2°F**

- Both ramp-up and ramp-down logic to prevent peak demand from exceeding that expected without the DR implementation

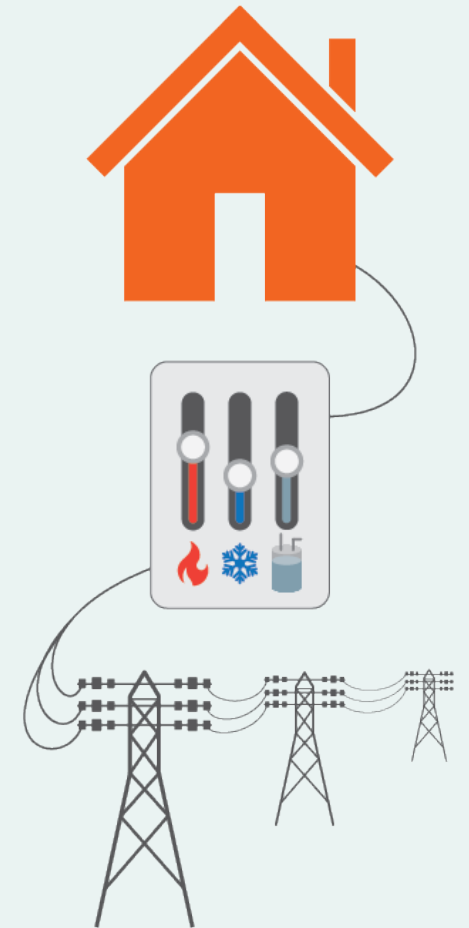

Additional Efficiency Measures (need 10 pts)

Section – Climate Zone (Group)	4A (B)	5A (B)	4A (R & I)	5A (R & I)	4A (E)	5A (E)
5% heat improvement	NA	1	1	1	1	1
10% heat improvement	3	2	1	1	2	1
5% cooling improvement	NA	2	1	2	2	3
10% cooling improvement+	5	4	2	1	4	2
Reduced lighting power+	8	7	2	2	8	8
Enhanced lighting controls	2	2	N/A	N/A	2	2
On-site renewable energy+	9	9	7	7	6	6
Dedicated outdoor air	5	5	6	8	N/A	N/A
Recovered/renewable water heat	N/A	N/A	14	14	1	1
Efficient water heater	N/A	N/A	8	9	2	2
Heat pump water heater	N/A	N/A	5	5	1	1
Enhanced envelope performance	7	10	4	4	1	2
Reduced air infiltration	8	11	7	9	N/A	1
Energy monitoring	3	2	1	1	2	2
Fault detection and diagnostics	1	1	1	1	1	1

Commercial HVAC

2018 IECC fault detection and diagnostics was only required on economizer systems

- High energy impacts if not working properly

Now, if 100,000 sf or larger facility, whole HVAC system required to have FDD system

- Permanently installed sensors monitoring HVAC performance
- Sample HVAC system performance on 15min intervals
- Automatically identify and report faults
- Automatically notify authorized personnel
- Automatically prioritize recommended repairs based on data analysis
- Transmit prioritized recommendations to remote personnel

R1 & R2 occupancies are excepted.

Sample HVAC FDD

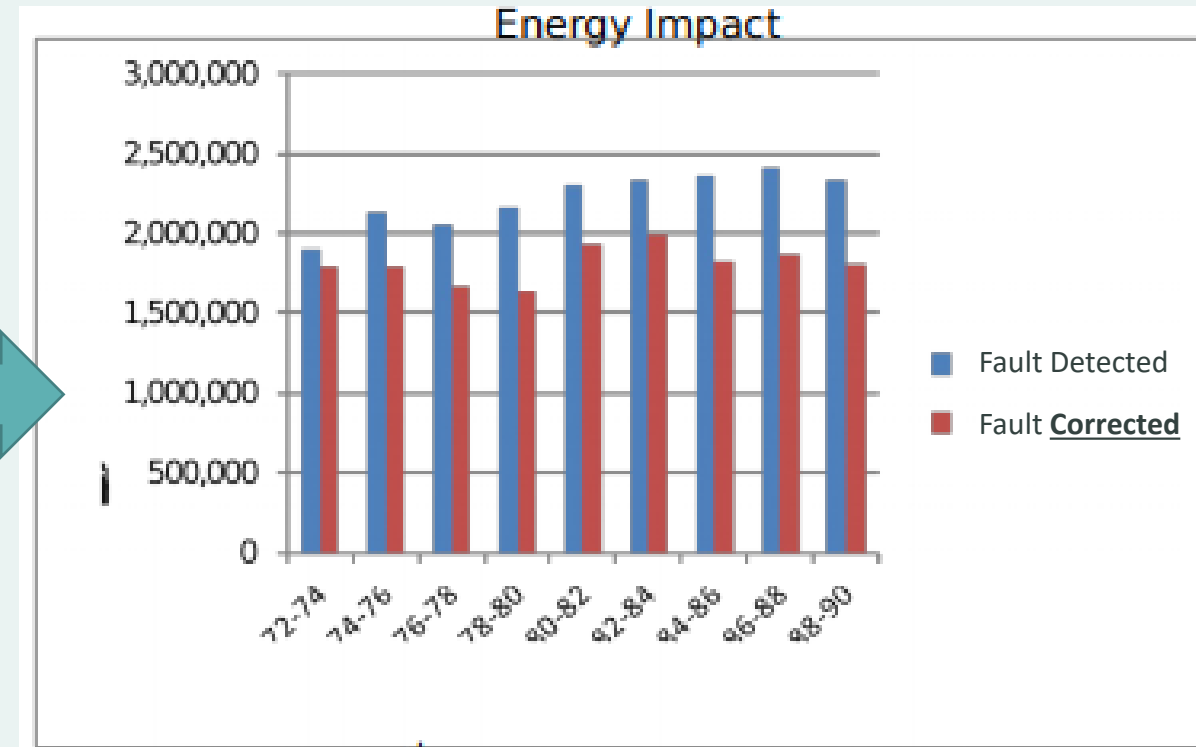
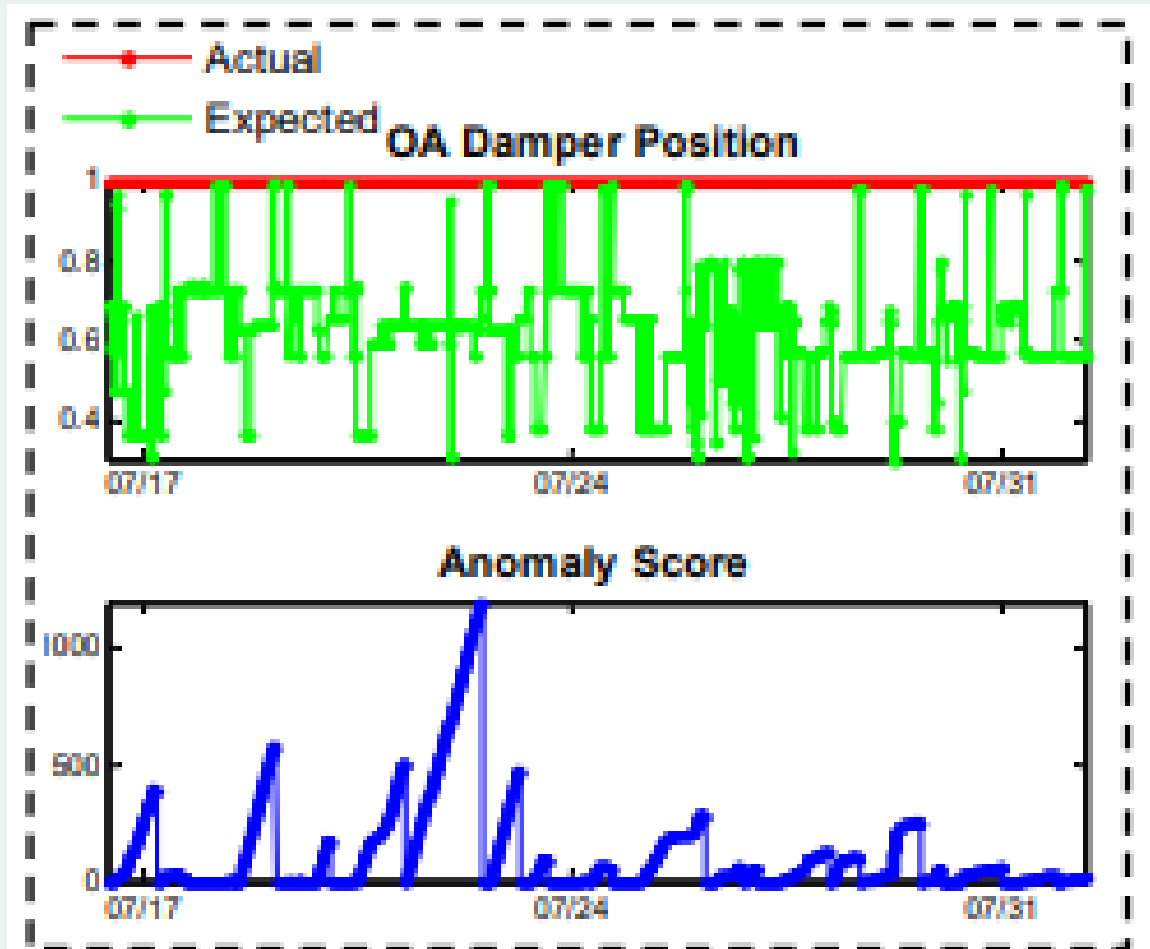

Image source: [University of Texas – San Antonio presentation at Clean Air Through Energy Efficiency Conference 2013](#)

Equipment Sizing

2018 IECC sizing language is maintained for most equipment

2021 IECC adds details on sizing for Data Center HVAC systems

- Must comply using modified ASHRAE 90.4 Sections 6 and 8
- HVAC component minimum efficiencies added to tables in section C403.3.2 HVAC equipment performance requirements

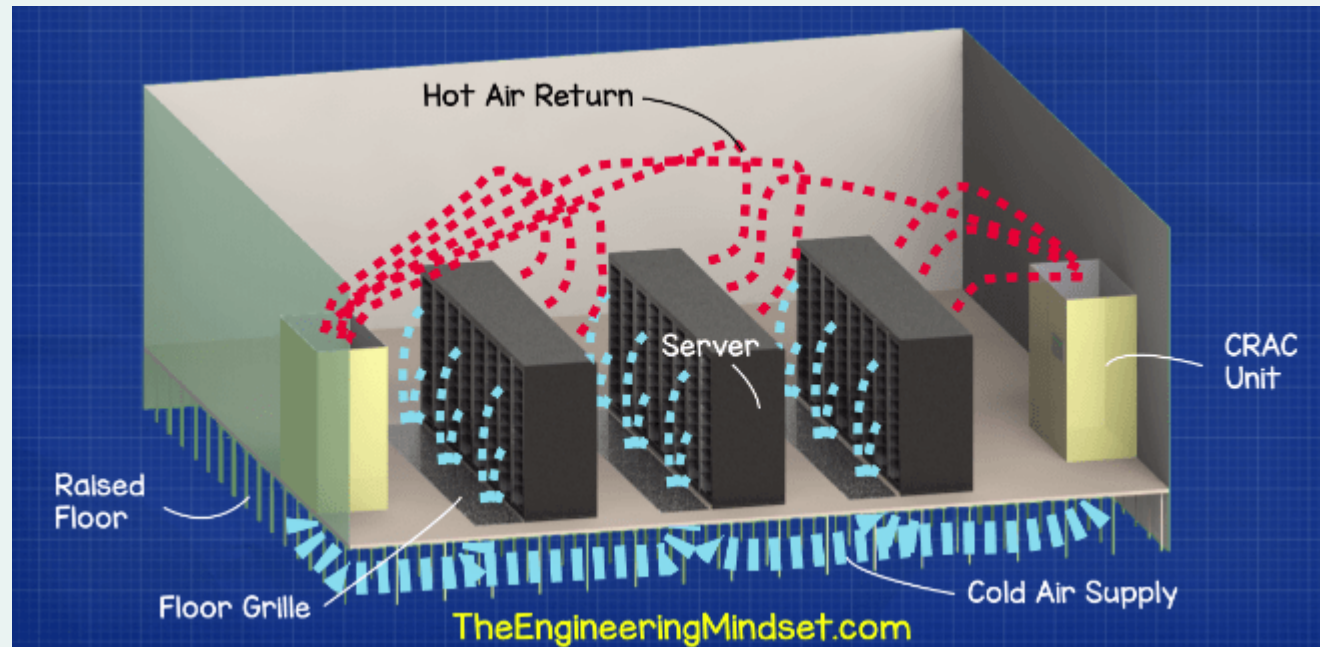

New Information!

Added minimum efficiency tables for:

- VRF systems
- Indoor pool dehumidifiers
- Dedicated outdoor air systems
- Heat pump and heat recovery chillers

Clarifications

Expanded or separated out table content for:

- Computer room air conditioners and condensing units
 - Floor mounted
 - Ceiling mounted
- Water-source heat pumps

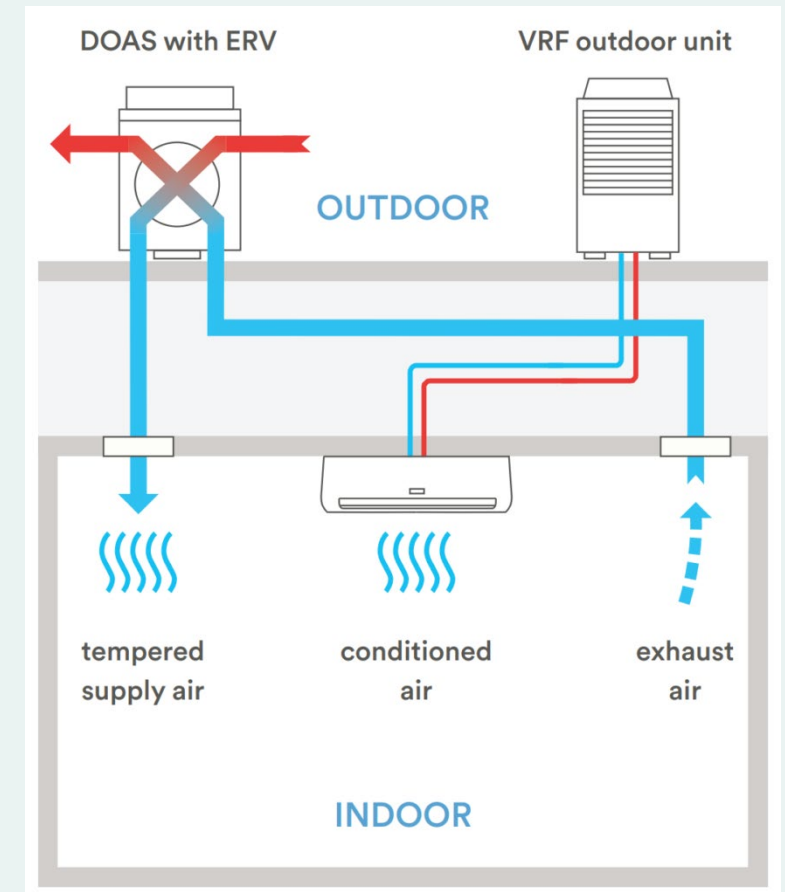

Unitary Air Conditioners or Heat Pumps
Increased efficiency and/or new testing
standard (SEER to SEER2)
Gas fired warm air furnaces



Image source: Warren Gretz / NREL



Image source: Dennis Schroeder / NREL



Image source: Dennis Schroeder / NREL

Supplemental Heat Prevention

- Heat pumps w/ supplemental electric resistance elements shall limit use only to times when one of the following apply:
 - Vapor compression cannot provide adequate heat
 - Heat pump is in defrost mode
 - Vapor compression malfunctions
 - Thermostat malfunctions

Note: 2018 only allowed when heat pump compressor could not meet heating load.



Image source: energyvanguard.com

Heat Pump Isolation

- Water source heat pump loops 10kW and larger require 2 position automatic valves interlocked with compressor

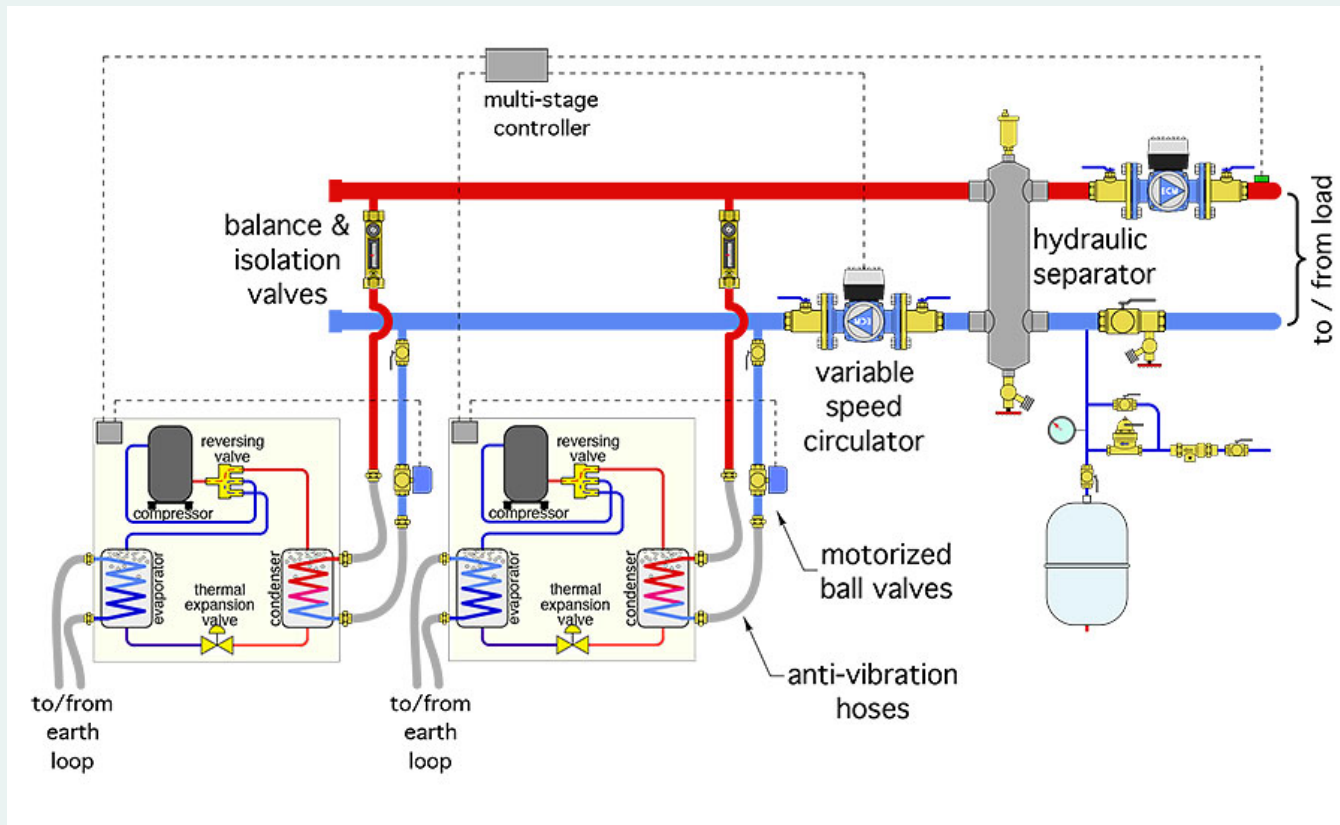
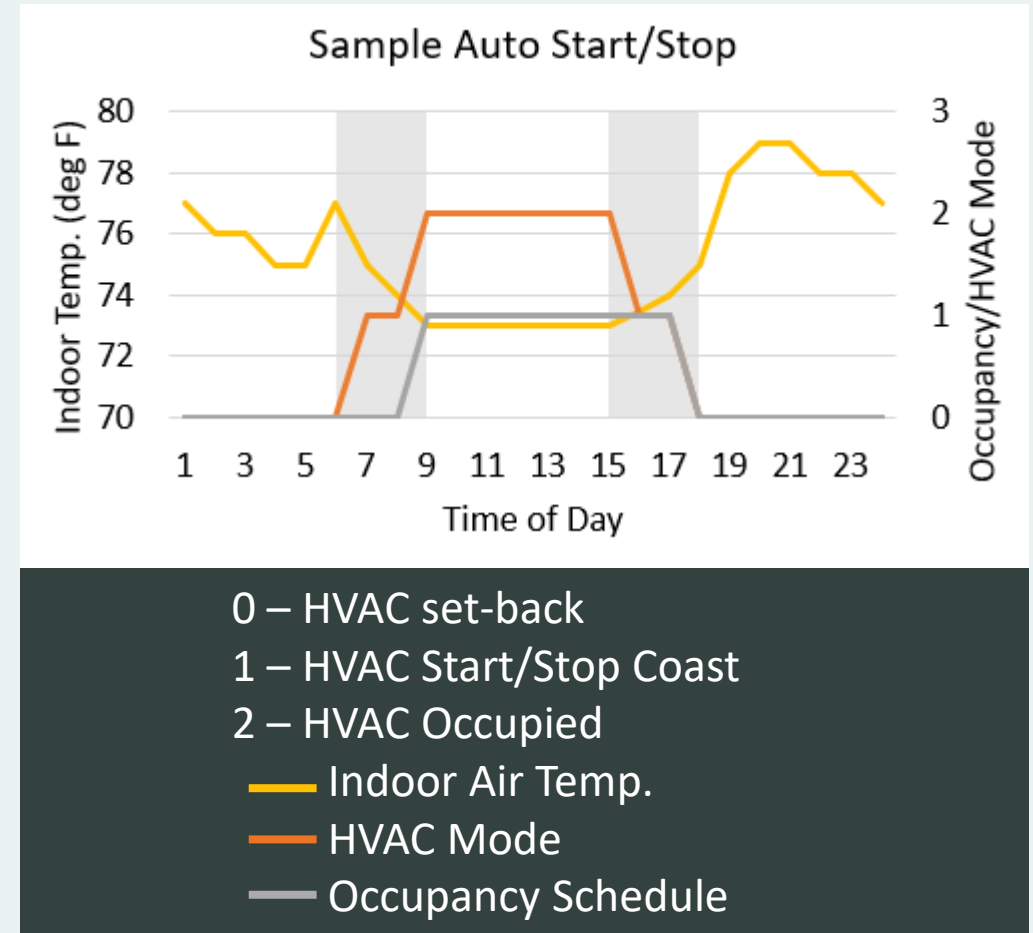

Image source: John Siegenthaler, Pmmag.com

Automatic Start/Stop

- Automatic **START** and **STOP**
 - Auto-start was 2018 requirement
 - Weather-adjusted HVAC start so building is at comfort conditions by time of occupancy
 - Auto-stop **added** for 2021
 - Not same as auto-off/set-back!
 - Sets back thermostats 2 degrees before scheduled unoccupancy to allow slow drift before occupants leave.



- C405.3 Exceptions added for VRF systems
 7. Economizers not required for VRF systems with a DOAS

Frequent question last year as code did not explicitly address VRF+DOAS systems.

Note: Previously, economizer might have been required for VRF-DOAS due to more vague language

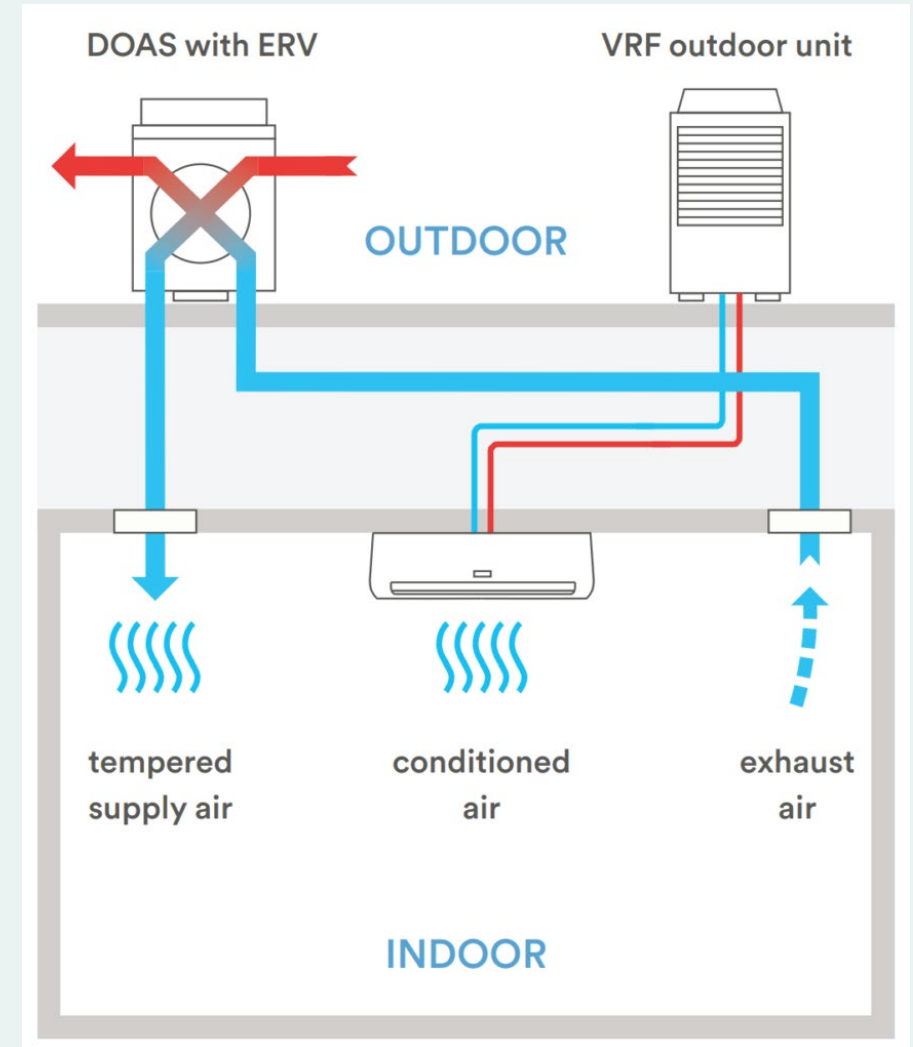

Image source: be-exchange.com

Economizer Fault Detection

- Monitor supply, return, and outside air temperatures
- Provide status on key system operations
- Report air temperature sensor faults, improper economizing, damper malfunctions, & excess OA flow.

Note: Failed economizers can dramatically increase energy consumption for heating/cooling. FDD is key to maintaining performance



Image source: [Honeywell](https://www.honeywell.com)

Example Economizer Trend Analysis

Common economizer controller for RTUs bottom left.

- Common errors include incorrect settings on controller, which is hard to read.
- Modern controllers have LCDs showing settings/set points to reduce setting errors in programming (center).
- Typically errors not found until RCx reviews trend logs
- FDD moves alerts to central station

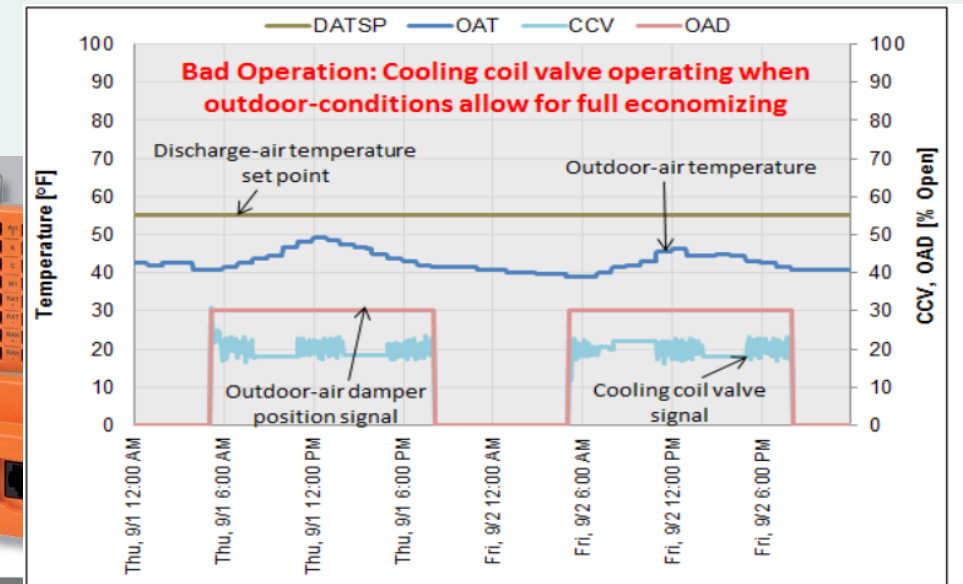
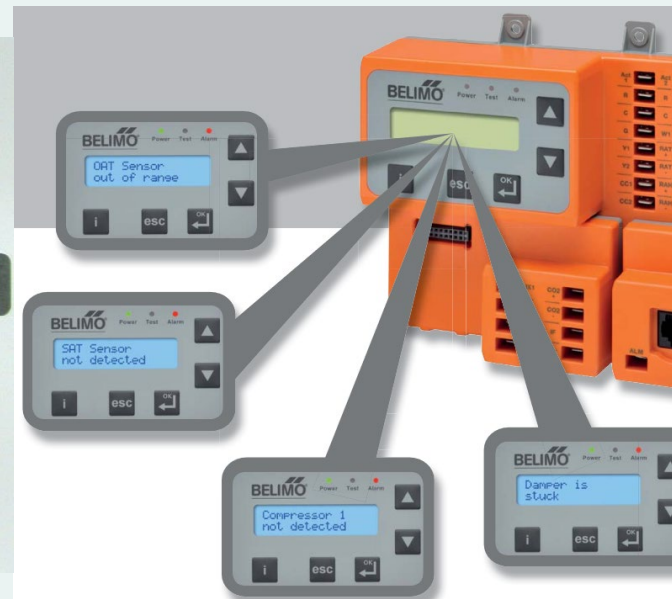
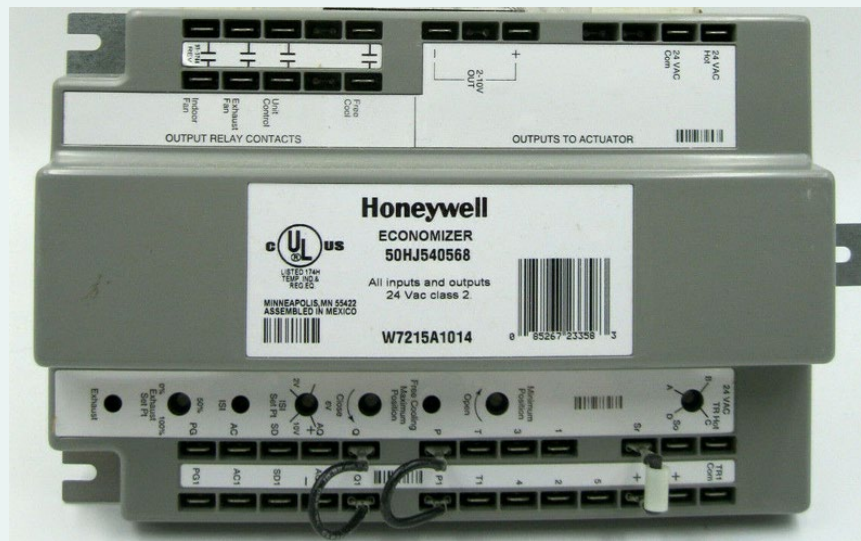

Figure 7: Cooling coil valve opening when outdoor conditions allow for full economizing, wasting cooling energy.

Demand Control Ventilation

2018 required DCV for spaces greater than 500sf with average occupant density of **25 ppl/1,000sf** or more.

2021 IECC updated to require for occupant density of **15ppl/1,000sf or more**

All other requirements unchanged

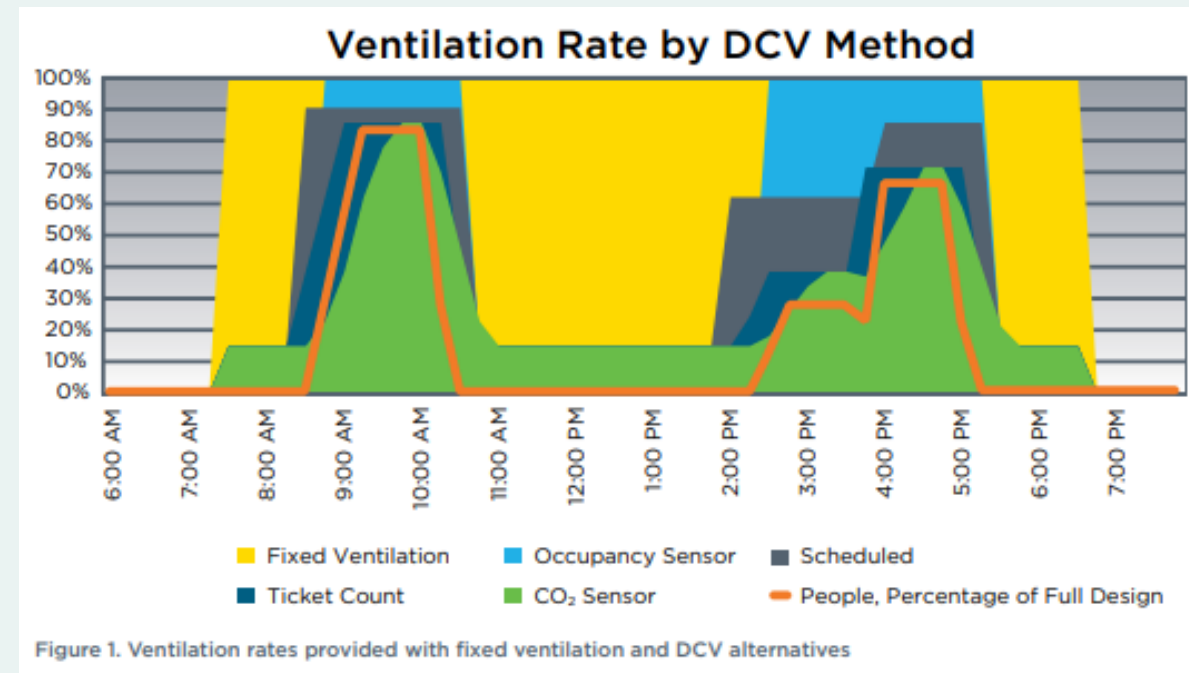

Image Source: Energycodes.gov

Exceptions also updated

- Exceptions:
 1. Systems with energy recovery complying with C403.7.4.2
 2. Multiple-zone systems without direct digital control of individual zones communicating with a central control panel
 3. Systems with a design outdoor airflow less than **750 cfm**
 4. **Spaces where more than 75% of space outdoor air is required for exhaust or transfer air**
 5. **Correctional cells, education laboratories, barber, beauty and nail salons, and bowling alley seating areas.**

Exceptions for parking garage ventilation have been made more stringent

- 2018 exception allowed for garage with total exhaust capacity of **22,500 cfm or less** that does not use mechanical heating.
- 2021 updates to **8,000 cfm or less**

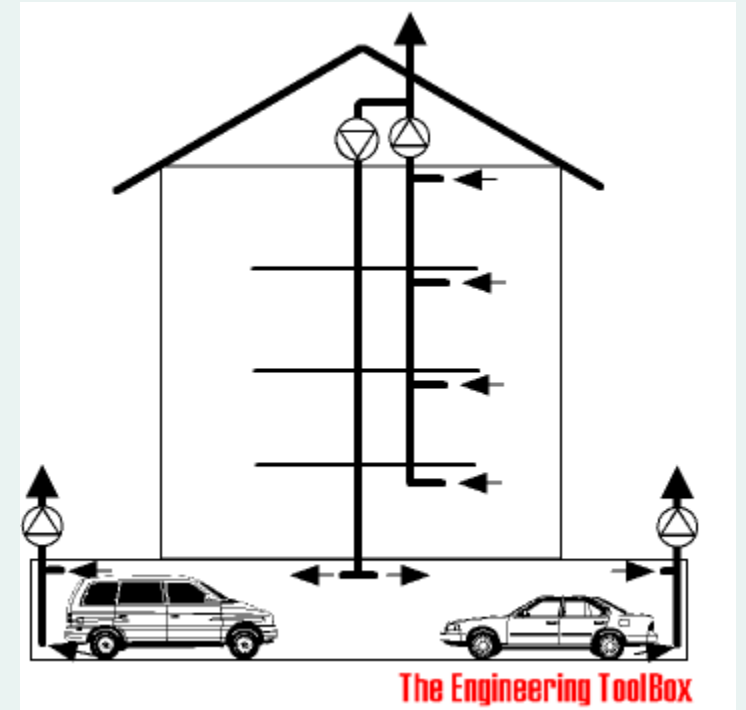

C403.7.4.1 Non-transient Dwelling Units

- Enthalpy recovery of 50% cooling design and 60% heating design
- The cooling enthalpy recovery ratio is excepted for Climate Zones 4 & 5
 - Best performance on cooling side with heating meeting 60% enthalpy recovery ratio.

C403.7.4.2 All Other Spaces

- Tables unchanged from 2018 IECC
- Exceptions have updates, but not applicable to IL Climate Zones.

Tables C403.7.4.2 (1) & (2) for CZ 4A and 5A summary

Operating Hours	Outdoor Air @ Full Design Flow Rate							
	10%- 20%	20%- 30%	30%- 40%	40%- 50%	50%- 60%	60%- 70%	70%- 80%	80%+
<8,000hr/yr	26,000+	16,000+	5,500+	4,500+	3,500+	2,000+	1,000+	120+
8,000+hr/yr	200+	130+	100+	80+	70+	60+	50+	40+

Guestroom HVAC Controls

- For buildings with **>50 guest rooms**
 1. Rented *but* unoccupied
 - Adjust setpoint by at least **4F** within **30 min** of occupants leaving
 2. Unrented *and* unoccupied
 - Adjust setpoints to **80F** and **60F** within:
 - **16 hours** without continuous occupancy
 - **20 minutes** after unoccupancy is indicated by networked guestroom control
 3. When occupied, return to normal setpoints when occupancy sensed



Fan Efficiency

Now Uses Fan Energy Index

1.00 or higher

VAV fans can have FEI of 0.95

*Exclusions for smaller fans/arrays,
ceiling fans, high temperature fans,
fans used in explosive atmosphere,
and emergency fans*

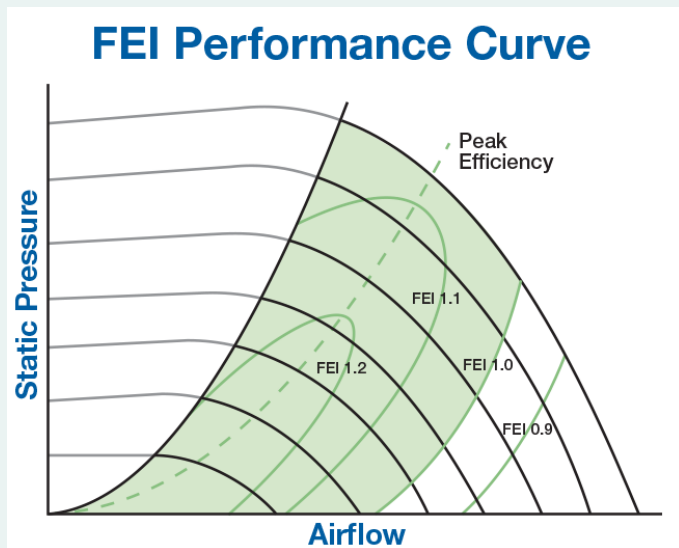

Photo Courtesy of Greenheck

Low-capacity ventilation fan efficacy

- For mechanical ventilation system fans less than 1/12 hp
 - Excludes ventilation fans as a component of a listed heating or cooling appliance
 - Dryer exhaust & range hoods that operate intermittently

Fan Location	Airflow Rate (CFM)	Minimum Efficacy (CFM/watt)
HRV or ERV	Any	1.2
In-line Fan	Any	3.8
Bathroom, utility room	10 to <90	2.8
Bathroom, utility room	90+	3.5

Commercial Lighting

Dwelling Lighting Equipment (Mandatory)

- Not less than 90% of the permanently installed fixtures shall contain only high-efficacy lamps



**Different from Residential
Building Provision!**

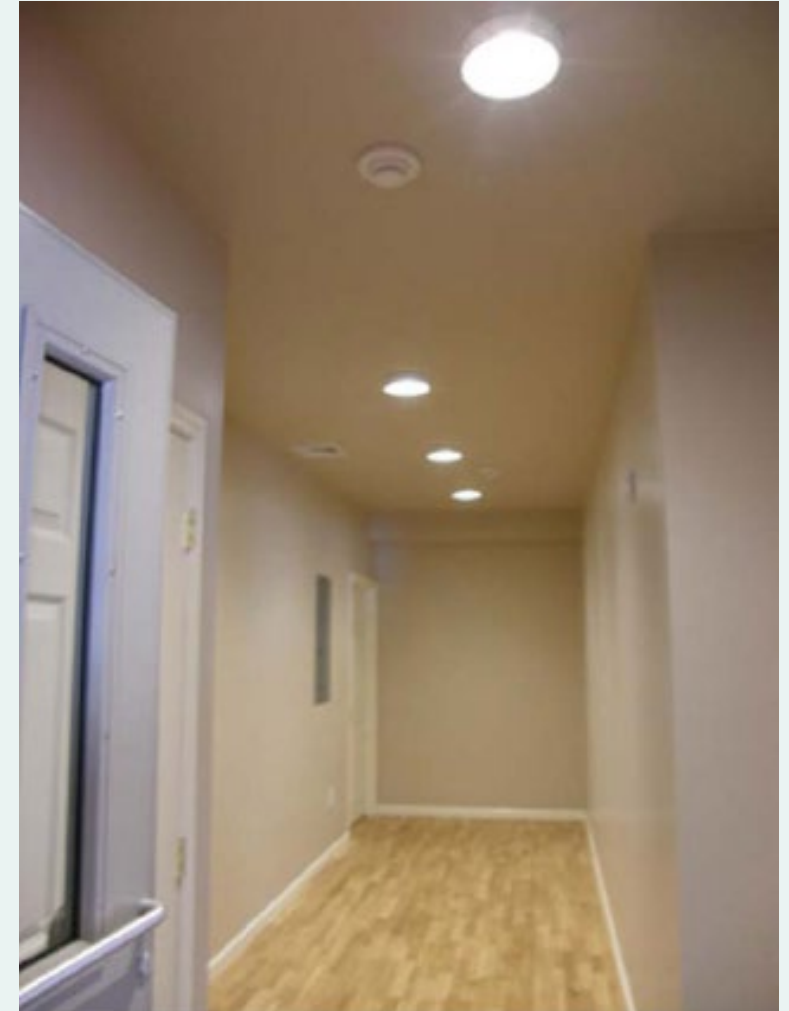

Occupant sensing controls are required in

1. Classrooms/lecture/training rooms
2. Conference/meeting/multi-purpose rooms
3. Copy/print rooms
4. Lounges/breakrooms
5. Enclosed offices
6. Open plan office areas
7. Restrooms
8. Storage rooms
9. Locker rooms
- 10. Corridors**
11. Other spaces 300 sf or less enclose by floor-to-ceiling height partitions
12. Warehouse storage areas



Occupant Sensor Control Function in *Warehouse*

- Must reduce lighting power by **at least 50%** when unoccupied.
- Controls must cover aisles and open areas.
- Control for each aisleway shall be independent and shall not control beyond the aisleway.



1. Zones limited to **600 sf**
2. Must reduce lighting power by **at least 80%** in a reasonably uniform pattern within 20 minutes after no occupancy
3. Turn off general lights in all zones within **20 minutes** of occupants leaving
4. Daylight responsive controls may activate fixtures only if occupants present



Image from <https://www.focalpointlights.com>

Occupant Sensor Control Function in *Corridors*

1. Must reduce lighting power by **at least 50%** in a reasonably uniform pattern within 20 minutes after no occupancy

Exception for corridors with less than 2 fc on floor at darkest point with all lights on.



Image from <https://cltc.ucdavis.edu/adaptive-corridors>

1. Auto-off within **20 minutes** of occupants leaving.
2. Manual-on or can be auto-on if not more than 50% power.
3. Shall incorporate manual control to allow occupants to turn lights off.
 - a. *Exception: Full auto-on **without manual control** permitted where manual operation would endanger the safety or security.*

Image from <https://lightingcontrolsassociation.org>



Light-reduction Controls

1. Manual control to uniformly reduce lighting by at least 50%. **Include an intermediate step between 70% and 30% power or with continuous dimming control (min of 20% or less)**
 1. Control all lamps/luminaires
 2. Switching alternate rows or luminaires
 3. Switching inner/outer lamps
 4. Switching each lamp/luminaire
2. *Exceptions for:*
 1. *Spaces with daylight responsive or special application controls*
 2. *Manually-controlled spaces with:*
 1. *Spaces with 1 luminaire rated less than 60 watts*
 2. *Spaces <0.45 watts/SF*
 3. *Corridors, lobbies, electrical / mechanical rooms*

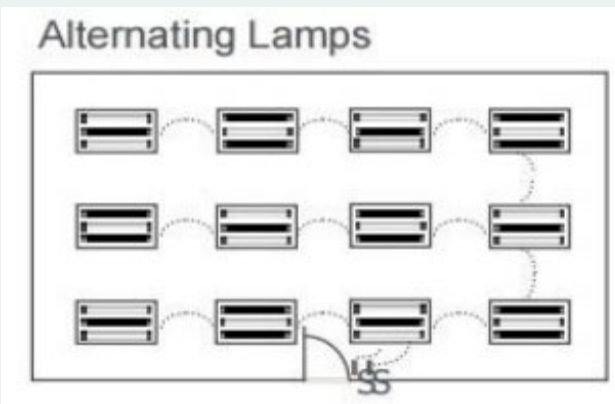
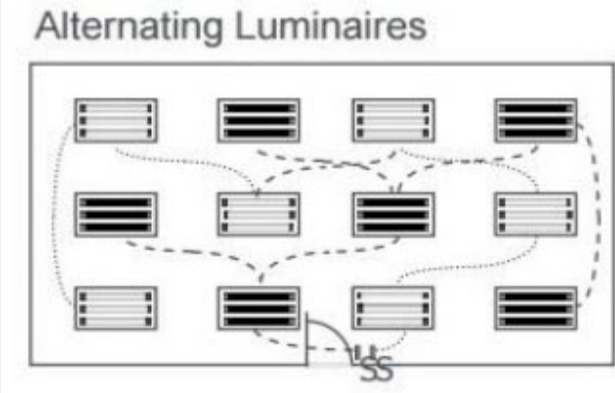
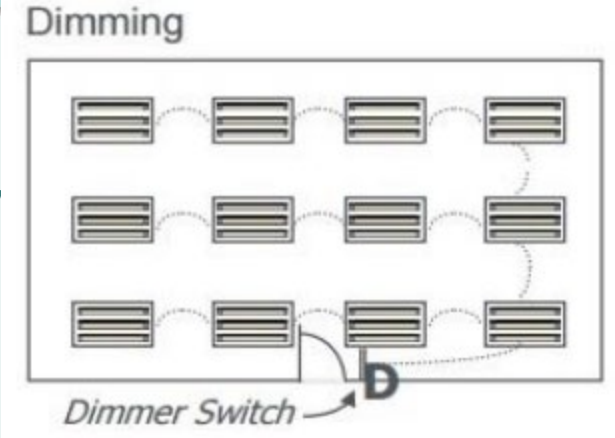

Exception

Connected lighting power < Adjusted lighting power budget

Adjusted lighting power budget
=

Normal lighting power budget * (1.0- [0.4* weighted avg of SF in daylit zone])

If below this threshold, no daylight controls required



Daylight Controls

Example Office 1:

200,000 sf total area

100,000 sf daylit zones

LPD: 0.79 W/sf

LPA: 158,000 W

LPA adj

= 158,000 W x (1.0 –
0.4x100,000/200,000)

= 158,000 W x 0.8

= 126,400 W (**20% less**)

Example Office 2:

200,000 sf total area

50,000 sf daylit zones

LPD: 0.79 W/sf

LPA: 158,000 W

LPA adj

= 158,000 W x (1.0 –
0.4x50,000/200,000)

= 158,000 W x 0.9

= 142,200 W (**10% less**)

Daylight Controls

Required in the following spaces:

1. >150 W of general lighting in primary sidelit zone
2. >300 W of general lighting in primary & secondary sidelit zone
3. >150 W of general lighting in toplit zone

Exceptions:

Health care facilities where patient care is directly provided

Lighting required for specific application control per C405.2.4

Sidelit zones on 1st floor above grade in Group A-2 (assembly uses for food/drink) and Group M (mercantile) occupancies



Daylight Control Functions

1. Toplit and sidelit separately controlled (150W overlap allowed)
2. Primary daylit zones controlled independently from secondary zones
3. Must be able to be calibrated within the space
4. Calibration mechanism must be readily accessible
5. Must dim continuously down to at least 15%
6. Must be able to turn lighting completely off
7. Cannot brighten lights beyond unoccupied setpoint set by occupant sensing controls
8. Sidelit zones of different cardinal directions controlled independently
Exception: < 150 W in each space can be controlled together.

Sidelit Zones

- Floor area adjacent to vertical fenestration
- Area of fenestration ≥ 24 sf
- Visible Transmittance ≥ 0.20

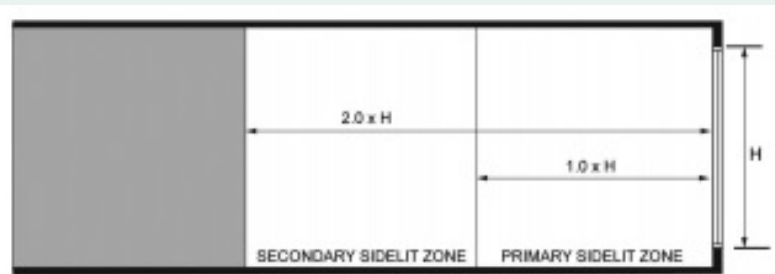

(a) Section view

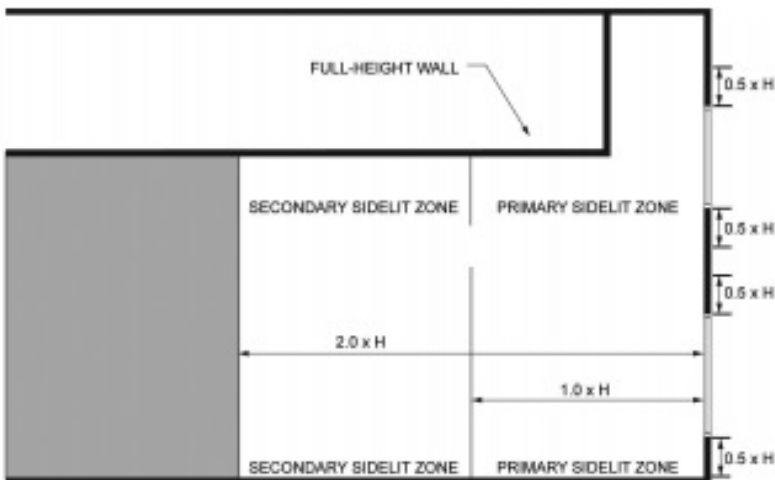

(b) Plan view

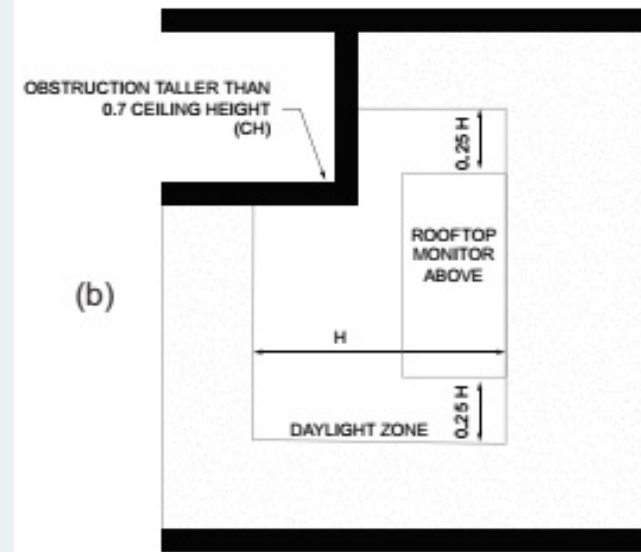
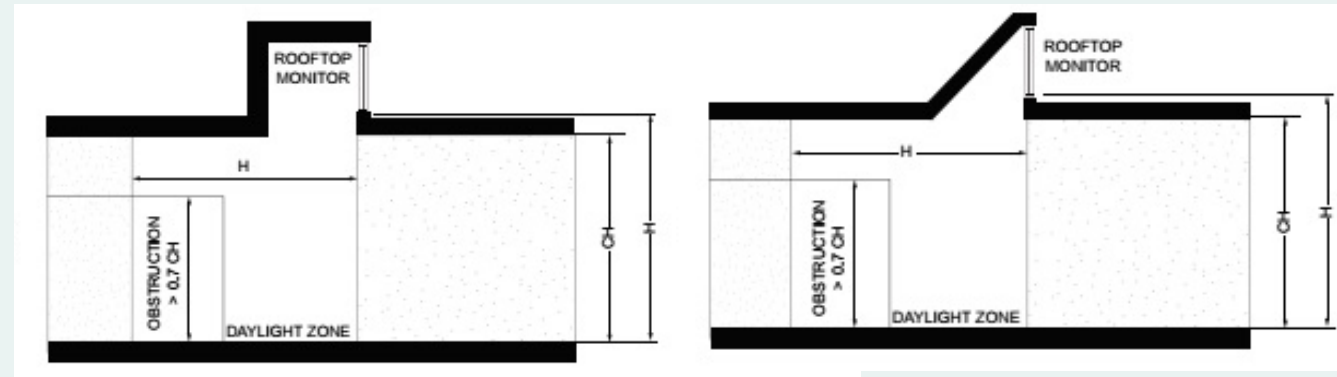

Toplit Zones

- Floor area underneath a roof fenestration
- No buildings block direct sunlight hitting the fenestration at the peak solar angle
- $(VT \times \text{area of roof opening}) / \text{toplit zone area} \geq 0.008$

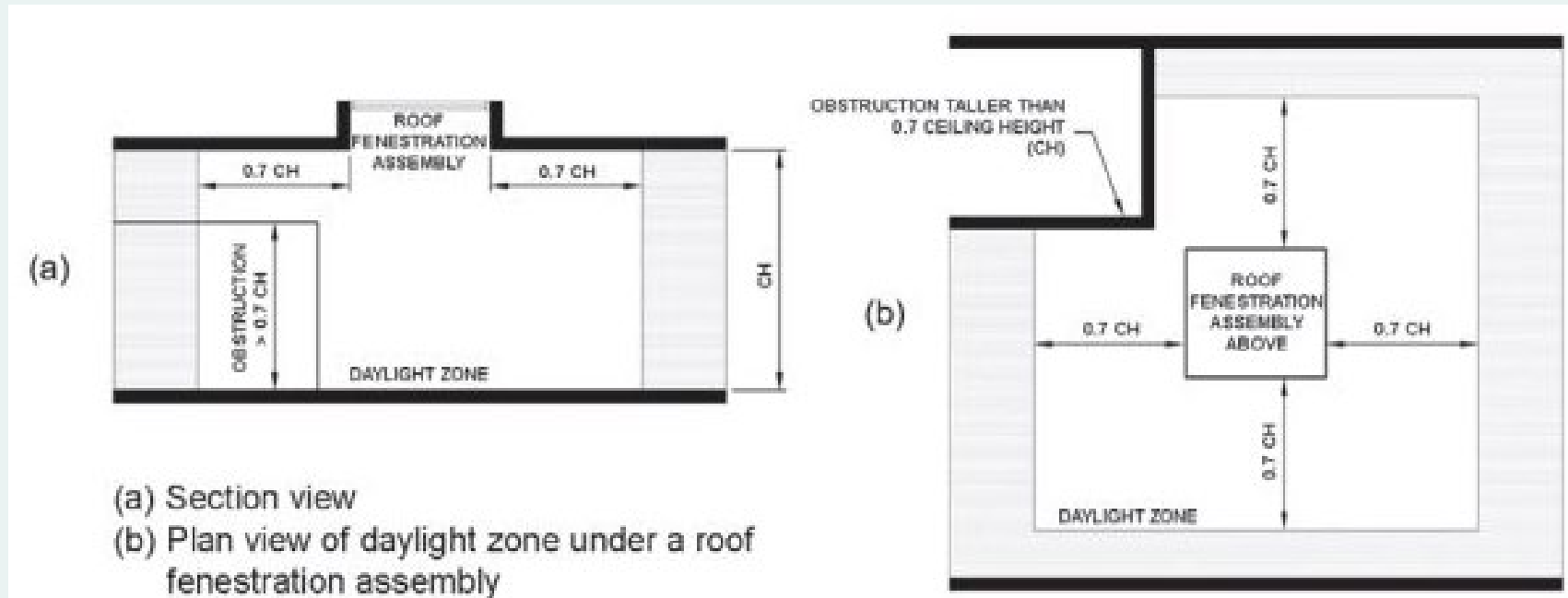
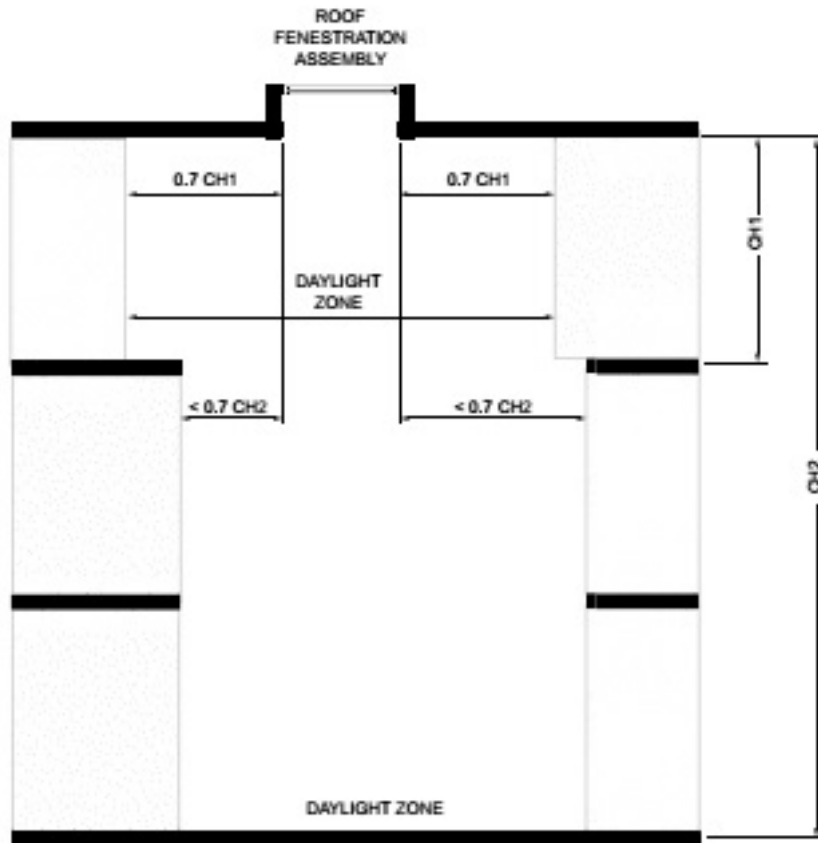

FIGURE C405.2.3.3(1)
TOPLIT ZONE

Atriums

- Daylight zones established on top floor and atrium floor, but no intermediate floors as shown.



(a) Section view of roof fenestration assembly at atrium

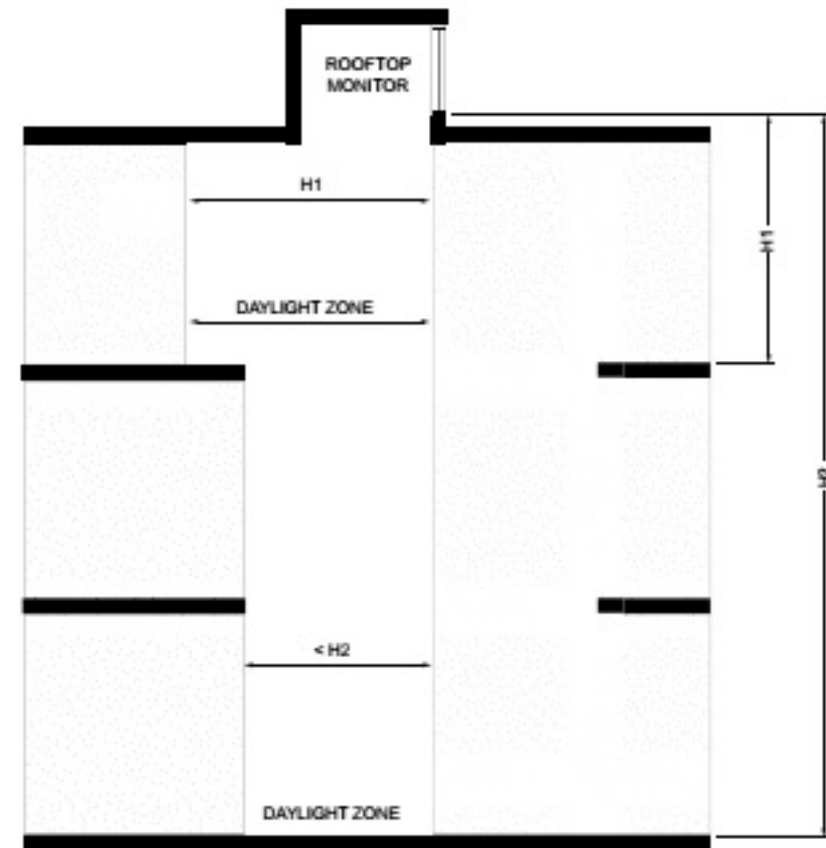

(b) Section view of roof monitor at atrium

Façade & Landscape Lighting

C405.2.7 Exterior Lighting Control

Exterior Lighting

C405.2.7.1

C405.2.7.3

C405.2.7.4

Decorative Lighting

C405.2.7.1

C405.2.7.2

C405.2.7.4

C405.2.7.1:
Daylight Shutoff

C405.2.7.2:
Decorative Lighting Shutoff

C405.2.7.3:
Lighting Setback

C405.2.7.4:
Time-switch Function

Exterior Lighting Controls

- **Daylight Shutoff**
- **Façade and Landscape Lighting**
 - Automatically shutoff ≤ 1 hr after business closing to ≤ 1 hr before opening
- **Lighting Setback**
 - Total wattage reduced by $\geq 50\%$ by switching or dimming during one of the following:
 - From not later than midnight to not earlier than 6 am
 - From ≤ 1 hour after business closing to ≤ 1 hour before opening
 - During any time where activity has not been detected for ≥ 15 min
 - Luminaires >78 W and 24ft or less above ground requires occupant sensing
- **Time-switch Control**
 - Same as interior time-switch



Parking Garage Lighting Controls

- Daylight responsive controls, w/i 20 feet of perimeter wall openings, reduce lighting power by **at least 50%** (*when daylight is present*)
- Occupant sensing to reduce lighting power by **at least 30%** within **20 minutes** of inactivity excluding zones provided with less than 1.5 fc on the floor at the darkest point with all lights on
- Eye adaption zones to be controlled separately, controls reduce power by at least 50% sunset to sunrise



Image source: energy.gov

Total Connected Interior Lighting Power

Total Connected Interior Lighting Power calculations must include the following:

- Lamp wattage label for line voltage lamps
- Ballast/transformer input wattage
- LED driver input wattage
- Track lighting (connected wattage, transformer wattage, or 8W/ft, whichever is greater)

Interior Lighting Power Allowance

- Building Area Method
- Space by Space Method w/ additional allowances for special use lighting

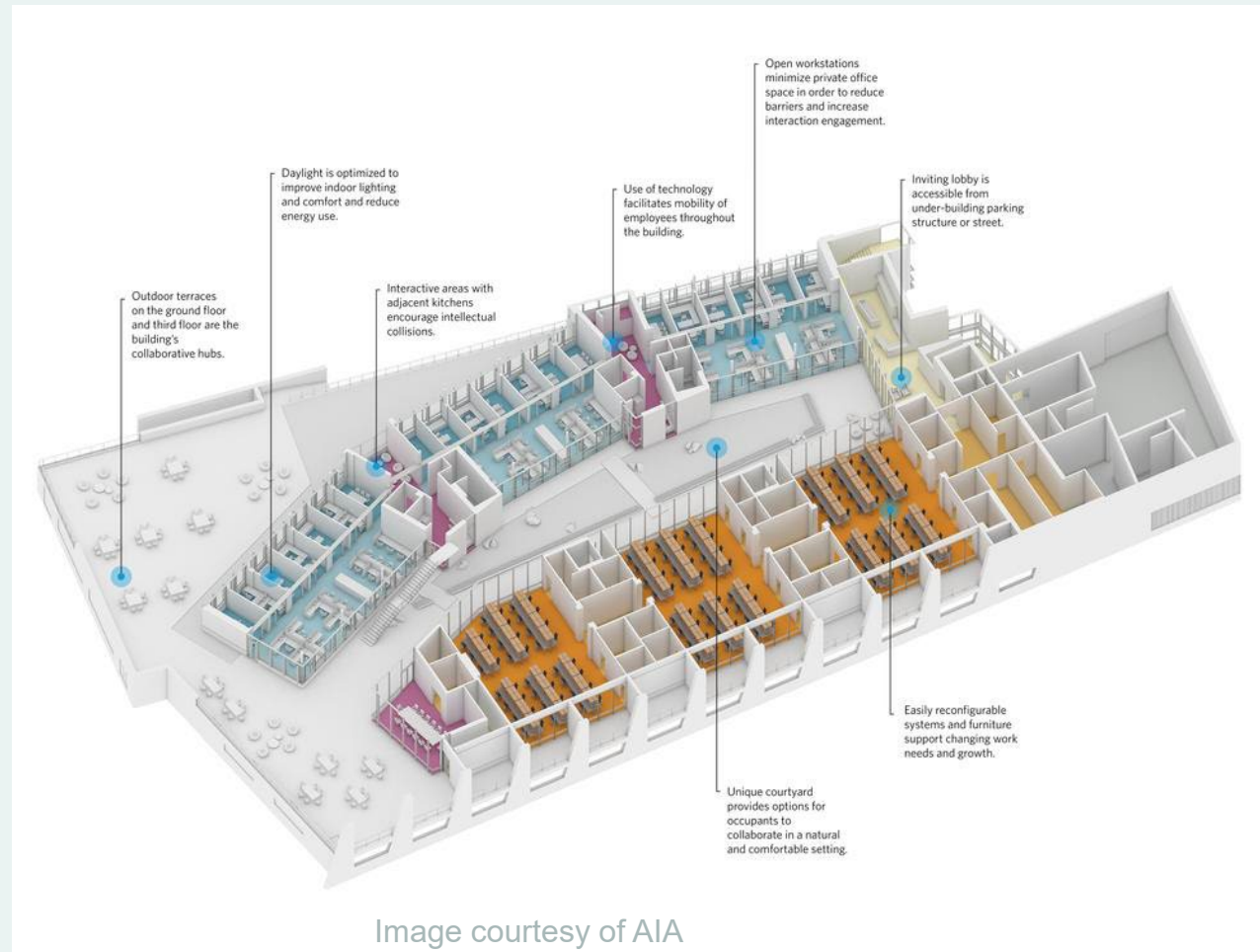

Table
C405.3.2 (1)

Interior LP Allowances: Bldg Area Method

Bldg Area Type	2018 IECC (W/SF)	2021 IECC (W/SF)	% Improvement
Automotive facility	0.71	0.75	-6%
Convention Center	0.76	0.64	16%
Courthouse	0.90	0.79	12%
Dining: Bar lounge/leisure	0.90	0.80	11%
Dining: cafeteria/fast food	0.79	0.76	4%
Library	0.78	0.83	-6%
Dormitory	0.61	0.53	13%
Workshop (highest category)	0.90	0.91	-1%

Lighting for Plant Growth

- All permanent installed luminaires shall have photon efficiency of not less than **1.7 $\mu\text{mol}/\text{J}$** per ANSI/ASABE S640 for greenhouses and **2.2 $\mu\text{mol}/\text{J}$** for all other indoor growing spaces

Exceptions for buildings with no more than 40k of aggregate horticultural lighting load and Cannabis facilities subject to 410 ILCS 705/10-45



Image courtesy of DOE

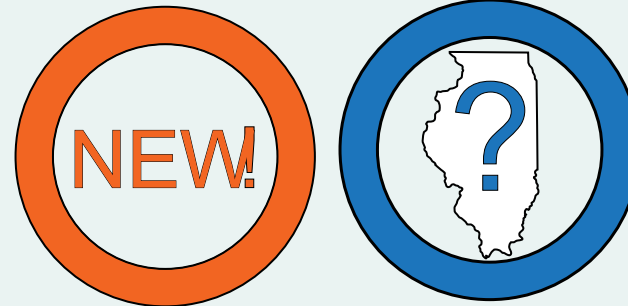

Exterior Lighting Power Allowance

Table C405.4.2(1) partial

Exterior Allowance	Zone 1	Zone 2	Zone 3	Zone 4
Base allowance	350	400	500	900 W
Parking/drives	0.03	0.04	0.06	0.08 W / sf
Walkways <10' wide	0.5	0.5	0.6	0.7 W / lf
Walkways, other	0.1	0.1	0.11	0.14 W / sf
Landscaping	0.03	0.04	0.04	0.04 W / sf
Entry canopies	0.2	0.25	0.4	0.4 W / sf



Automatic Receptacle Control

- At least 50% of receptacles in all enclosed offices, conference rooms, rooms used primarily for print and/or copy functions, break rooms, classrooms, and individual workstations.
- At least 25% of *branch circuit* feeders installed for modular furniture not shown on the *construction documents*.

Time of day basis, occupant, or control signal based



Image by Leviton

Measurement devices shall be installed in new *buildings* to monitor the electrical *energy* use for:

- a. HVAC systems
- b. Interior lighting
- c. Exterior lighting
- d. Receptacle circuits
- e. Large process loads
- f. Building operations/Misc



Residential Definitions

2018 IECC:

“Demand Recirculation Water System: A water distribution system having one or more recirculation pumps that pump water from a heated water supply pipe back to the heated water source *through a cold water supply pipe*”

2021 IECC:

“Demand Recirculation Water System: A water distribution system where one or more pumps prime the service hot water piping with heated water upon demand for hot water.”

Refer to **R403.5.1.1.1** for Demand Recirculation Water System Requirements.

New Definitions:

“**On-site Renewable Energy:** Energy from renewable energy sources harvested at the building site.”

“**Renewable Energy Certificate (REC):** An Instrument that represents the environmental attributes of one megawatt hour of renewable energy; also known as an energy attribute certificate (EAC).”

“**Renewable Energy Resources:** Energy derived from solar radiation, wind, waves, tides, landfill gas, biogas, biomass or extracted from hot fluid or steam heated within the earth.”

2018 IECC:

“Roof Re-cover: The process of installing an additional roof covering over a *prepared* existing roof covering without removing the existing roof covering.”

2021 IECC:

“Roof Re-cover: The process of installing an additional roof covering over an existing roof covering without removing the existing roof covering.”

Air-impermeable insulation

R303.1.5 is a new section for 2021 giving a precise definition for materials considered 'air-impermeable insulation' which must meet the requirement below.

- Insulation having air permeability not greater than 0.004 cfm/sf at 0.3 inch water gauge (75 pascals)
- Must be tested in accordance with ASTM E2178



Permeable insulation examples: Cellulose, Mineral Wool, Fiberglass
https://energyeducation.ca/encyclopedia/Fibrous_insulation

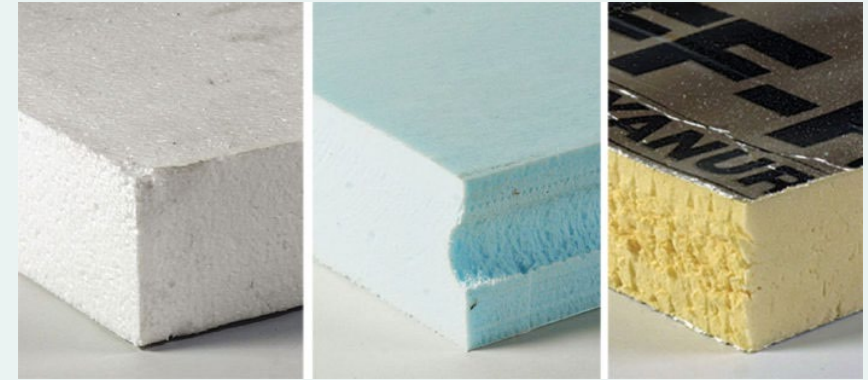

Impermeable insulation examples: EPS, XPS, Polyiso
<https://www.greenbuildingadvisor.com/article/choosing-rigid-foam>

Residential

R401.2.5 lays out requirements for improving efficiency over base compliance paths: Targets 5% improvement over base code-compliance building

- **Prescriptive Compliance:**

- Select an additional efficiency package from R408 to implement

- **Total Building Performance Compliance:**

- Include R408 package but do not model in proposed design
- Include R408 package in proposed design, and achieve 5% energy cost reduction over standard reference design

- **Energy Rating Index Compliance:**

- ERI value shall be 5% less than specified in Table R406.5
- ERI targets returns to 2015 IECC levels (more stringent!)



Passive House Certified: No additional requirements (IL Amendment)

- **Efficient Envelope Performance**
 - 5% reduction in UA over Table R402.1.2.
 - SHGC shall be 5% less than Table R402.1.2 values
- **Efficient HVAC Equipment Performance**
 - 95% AFUE/10 HSPF heating with 16 SEER cooling
 - 3.5 COP ground-source heat pump
 - All systems must comply for multi-system residences
- **Reduced Service Hot Water Energy**
 - 0.82 EF gas, 2.0 EF electric, and 0.4 solar fraction water heaters

- **Efficient Duct Thermal Distribution**
 - 100% of ducts within thermal envelope
 - 100% ductless or hydronic within thermal envelope
 - 100% within conditioned space per R403.3.2
- **Improved Air Sealing and Ventilation**
 - Air leakage of 3.0 ACH₅₀ or less with ERV or HRV
 - 75% sensible recovery + 50% latent recovery when applicable
 - 1.1 cfm/watt or less fan efficiency
 - Cannot use recirculation for defrost

The Total Building Performance Compliance path has been reorganized and clarified.

R405.2: A proposed design must meet the following requirements:

1. Meet requirements of all sections indicated in Table R405.2
2. Proposed design has an annual energy cost that is less than or equal to the annual energy cost of the standard reference design.

Any proposed design must also meet the following envelope **performance backstop**.

- Building thermal envelope shall be greater than or equal to levels of efficiency and SHGCs in Table R402.1.1 or R402.1.3 of the **2009 IECC**.

Maximum Energy Rating Index

Climate Zone	2018 ERI Target	2021 ERI Target
4	62	54
5	61	55

Return to 2015
IECC ERI Targets!

Recall with Additional Efficiency Packages:

1. Meet this score and then include one package OR
2. Model the efficiency package and have 5% reduction in ERI

Envelope performance backstop requirement if renewables not included: $UA_{\text{proposed}} \leq 1.15 \times UA_{\text{reference}}$

With renewables, envelope performance backstop is 2018 IECC

Energy Certificate

Added requirement to list on-site PV capacity, inverter efficiency, and panel tilt/orientation if installed.

Ensure certificate does not cover other safety or informational tags when installed!
Other requirements unchanged. Display:

- Weighted average or largest portion R-values
- Display window U-factors and SHGCs
- Air & duct leakage test results
- Type and Efficiency of HVAC systems
- Code version for compliance

Energy Code Certificate			
Name of Designer/Builder:		DATE:	
Energy Code edition:		Compliance Path:	
1. Insulation Rating		R-Value	R-Value
Ceiling /Roof	Attic	<input type="text"/>	Vaulted <input type="text"/>
Walls	Frame	<input type="text"/>	Mass <input type="text"/>
	Basement	<input type="text"/>	Crawl space <input type="text"/>
Floors	Over unconditioned space	<input type="text"/>	Slab edge <input type="text"/>
Ducts	Attic	<input type="text"/>	Other <input type="text"/>
2. Fenestration Rating		NFRC U-Factor	NFRC SHGC
Window		<input type="text"/>	<input type="text"/>
Opaque door		<input type="text"/>	<input type="text"/>
Skylight		<input type="text"/>	<input type="text"/>
3. Air Leakage Test Results			
Blower door	<input type="text"/>	ACH/50 Pa.	Duct testing <input type="text"/>
			Cfm/100 ft ²
4. Equipment Performance		Type	Size
Heating system		<input type="text"/>	<input type="text"/>
Cooling system		<input type="text"/>	<input type="text"/>
Water heater		<input type="text"/>	<input type="text"/>
Indicate if the following have been installed:			
<input type="checkbox"/>	Electric furnace	<input type="checkbox"/>	Gas-fire unvented room heater
<input type="checkbox"/>		<input type="checkbox"/>	Baseboard electric heater
5. Photovoltaic Panel Systems			
Array capacity	<input type="text"/>	Panel tilt	<input type="text"/>
Inverter efficiency	<input type="text"/>	Orientation	<input type="text"/>
6. Energy Rating Index Score		Structure Permit	
<input type="text"/>	<input type="text"/>	<input type="text"/>	<input type="text"/>

smartenergy.illinois.edu/energy-code/ | 800.214.7954 | energycode@illinois.edu
Smart Energy Design Assistance Center, 1 St Mary's Road, Champaign, IL 61820

UNIVERSITY OF ILLINOIS SEDAC

[About](#)
[Programs](#)
[Who We Serve](#)
[Resources](#)
[Blog](#)
[Contact](#)

Energy Code Checklists

[Home](#) > [Energy Code Checklists](#)

Check out our checklists to help with energy code site inspection and compliance!

1. Insulation Rating		R-Value	R-Value
Ceiling /Roof	Attic	<input type="text"/>	Vaulted <input type="text"/>
Walls	Frame	<input type="text"/>	Mass <input type="text"/>
Floors	Basement	<input type="text"/>	Crawl space <input type="text"/>
	Over unconditioned space	<input type="text"/>	Slab edge <input type="text"/>
Ducts	Attic	<input type="text"/>	Other <input type="text"/>

2. Fenestration Rating		NFRC U-Factor	NFRC SHGC
Window	<input type="text"/>	<input type="text"/>	<input type="text"/>
Opaque door	<input type="text"/>	<input type="text"/>	<input type="text"/>
Skylight	<input type="text"/>	<input type="text"/>	<input type="text"/>

3. Air Leakage Test Results			
Blower door	<input type="text"/>	ACH/50 Pa	Duct testing <input type="text"/>
			CFm/100 ft ²

4. Equipment Performance			
	Type	Size	Efficiency
Heating system	<input type="text"/>	<input type="text"/>	<input type="text"/>
Cooling system	<input type="text"/>	<input type="text"/>	<input type="text"/>
Water heater	<input type="text"/>	<input type="text"/>	<input type="text"/>

Indicate if the following have been installed:

Electric furnace
 Gas-fired unvented room heater
 Baseboard electric heater

5. Photovoltaic Panel Systems	
<input type="text"/>	<input type="text"/>

Illinois Home Energy Code Checklist & Energy Certificate

🕒 June 16, 2022

For Homeowners and Realtors. Are you interested in buying an energy efficient home? Do you want to learn how to make your home more energy efficient? This checklist can help you quickly assess a home's energy performance and construction.



Residential Energy Code Checklist

🕒 March 2, 2021

For Building Code Officials, Architects, and Engineers. This Residential Energy Code Checklist is intended to assist with plan review and site inspection for the Illinois Energy Code.

Table
R402.1.2

Maximum Assembly U-Factors

IECC Year	Climate Zone	Fenestration U-Factor	Skylight U-factor	Fenestration SHGC	Ceiling U-Factor	Wood Frame Wall U-Factor	Mass Wall U-Factor	Floor U-Factor	Basement Wall U-Factor	Crawl Space Wall U-Factor
2018	4	0.32	0.55	0.40	0.026	0.060	0.098	0.047	0.059	0.065
	5	0.30	0.55	NR	0.026	0.060	0.082	0.033	0.050	0.055
2021	4	0.30	0.55	0.40	0.024	0.045	0.098	0.047	0.059	0.065
	5	0.30	0.55	0.40	0.024	0.045	0.082	0.033	0.050	0.055

Table
R402.1.3

Minimum Assembly R-Values

IECC Year	Climate Zone	Fenestration U-Factor	Skylight U-factor	Fenestration SHGC	Ceiling R-Value	Wood Frame Wall R-Value	Mass Wall R-value	Floor R-value	Basement Wall R-value	Slab R-value & Depth
2018	4	0.32	0.55	0.40	49	20 or 13+5	8/13	19	10/13	10, 2ft
	5	0.30	0.55	NR	49	20 or 13+5	13/17	30	15/19	10, 2ft
2021	4	0.30	0.55	0.40	60	30, 20+5, 13+10, or 0+20	8/13	19	10ci/13	10, 4ft
	5	0.30	0.55	0.40	60	30, 20+5*, 13+10, or 0+20	13/17	30	15ci/19/ 13+5ci	10, 4ft

*PHIUS notes for CZ-5 that R-20+R-5ci for framed walls can lead to condensation, thus R-30, 13+10ci or 0+20ci is recommended!

Access Hatches and Doors

R402.2.4: Clarity added to requirements for pull-down stair and vertical door attic access insulation

- **Vertical doors** comply with Table R402.1.3 requirements
- **Pull-down stairs** in Climate Zone 4 do not need to have insulation equivalent to attic if:
 - Hatch door is R-10 (U-0.10) or better
 - 75% of the panel area is R-13 or better
 - Opening net area is 13.5sf or less
 - Hatch perimeter is weather stripped



Image source: Energy.gov

R402.2.5: Access hatch insulation retention

- Language clarified for retention of loose-fill insulation around hatch

Floor Cavity Insulation

Floor cavity insulation must comply with one of the following:

1. Insulation must maintain contact with underside of the subfloor decking, or fill the available cavity
2. Cavity insulation can contact top of sheathing separating unconditioned space below.
3. A combination of cavity and continuous insulation can be installed such that the combined R-value equals the required value for floors from Table R402.1.3.

* 2 & 3: Insulation must be full depth at all perimeter framing members and all framing members shall be air sealed.

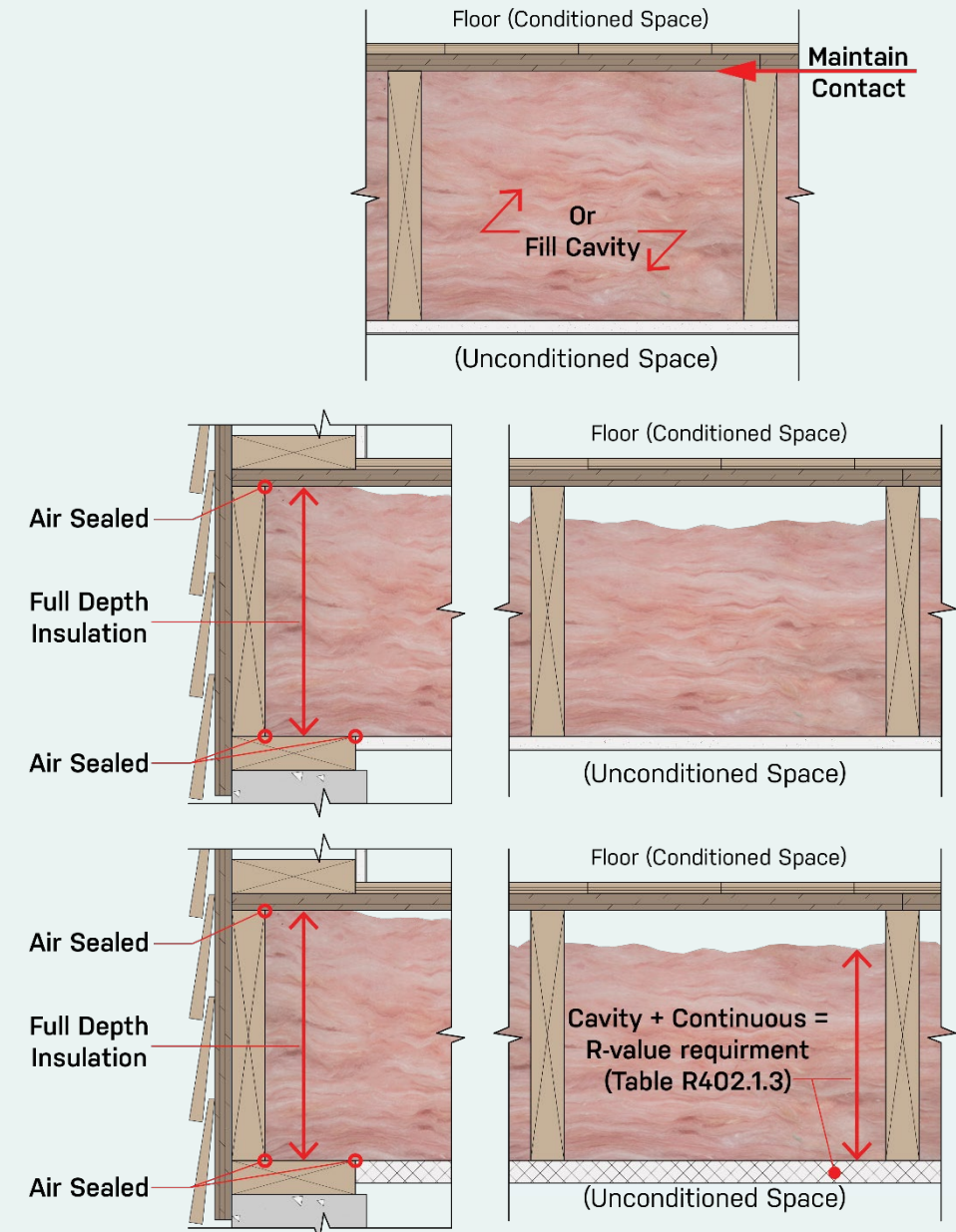

Basement Walls

Large portion added explaining insulation for unconditioned basements

- Insulate floor over basement, including stairwell stringers
- Ensure **no uninsulated ducts** or hydronic systems, and no supply/return diffusers
- Walls surrounding stairway to be insulated
- Door insulated per R402.1.3 / R402.2 and weather stripped



Image source: <https://blog.delafleur.com/?p=5944>

Sunrooms and Heated Garages

Added **heated garages** to sunroom section as similar low-energy space types

- Must be **thermally isolated** from other conditioned spaces
- CZ 4 minimum ceiling insulation: R-19
- CZ 5 minimum ceiling insulation: R-24
- Minimum wall insulation: R-13
- Wall separating sunroom or garage from other spaces **fully insulated** per Table R402.1.2



Image courtesy: www.energy.gov

Table R402.4.1.1 Air Barrier, Air Sealing, and Insulation reference table updated

- Expanded air sealing list for foundations
 - Exposed earth covered with Class 1 vapor retarder
 - Penetrations through slab shall be air sealed
 - Class 1 vapor retarders **SHALL NOT** be used as the air barrier on below-grade walls
 - Rim joists shall include an exterior air barrier **and** be air sealed to adjacent framing members
- Added detail for narrow cavities
 - Shall be air sealed if 1” or less and cannot be insulated.
- Added air sealing note around plumbing and utility penetrations



Image source: https://basc.pnnl.gov/slab_penetrations

Air Leakage Testing

Adds backstop to air leakage of 5.0 ACH for all compliance paths

Added testing exception for heated garages on 1- and 2-story homes and townhomes, must maintain thermal isolation.

Added specific procedure for **multi-family testing** (previously included as IL amendment)

- Enclosure area-based metric (0.30 cfm/sf) rather than ACH at 50 Pa
- Unguarded test – neighboring units not pressurized to same as test unit



Image source: <https://www.mncee.org/new-construction-services>

New section outlining air-sealing requirements for electrical and communications outlet boxes installed within the thermal envelope.

- Outlet boxes shall be tested in accordance with NEMA OS 4
- The tested air leakage rate shall not exceed 2.0 cfm at 75 Pa
- The outlet boxes shall be marked 'NEMA OS 4' or 'OS 4' and be installed per manufacturers instructions to achieve NEMA OS 4 compliance

Ducts in Unconditioned Space

- No changes to duct insulation requirements
 - R-8 wrap on ducts if 3” or more in diameter
 - R-6 wrap if less than 3” in diameter
 - Ducts under slab insulated as above or have **equivalent Thermal Distribution Efficiency (TDE)**.
 - If using TDE method, must be labeled and listed with equivalent R-value.

	A	B	C	D
1	Draft ASHRAE standard 152 duct efficiency calculations			
2	Jan-03		modified by PRC (location index and lookup values)	
3	Mar-11		fixed typo "Qemen" --> "Qeman" (NREL)	
4				
5	INPUT PARAMETERS			CALCULATED PARAMETERS
6		Value used in calculation	Notes	
7	Location Index	65	Chicago, IL	
8	Conditioned floor area, (ft ²)	1761		
9	Number of Stories	2		
10	Number of return Registers	3		Ground Temperature for basements, and slabs
11	House Volume, (ft ³)	14440	has a default of 8.2*Floor Area	
12	Supply Duct Surface Area, (ft ²)	357	has default equation	Fraction of supply duct outside conditioned space
13	Return Duct Surface Area, (ft ²)	198	has default equation	Fraction of return duct outside conditioned space
14	Fraction of supply duct in attic	1		Design Supply Duct Zone temperature, Heating, (F)

- TDE can be calculated using ASHRAE 152 methods. A spreadsheet is available at <https://www.energy.gov/eere/buildings/downloads/ashrae-standard-152-spreadsheet>

Ducts in Conditioned Space

- Clarifies definitions of conditioned space for ducts
 - Entirely within thermal envelope
 - Ductless or hydronic system within thermal envelope
 - Ducting within **conditioned space**
 - Buried in attic insulation and sealed to 1.5cfm/100sf floor area
 - Ducts in floor cavities must have R-19 between duct and unconditioned space
 - Ducts in exterior walls must have R-10 between duct and exterior sheathing; rest of cavity filled with insulation

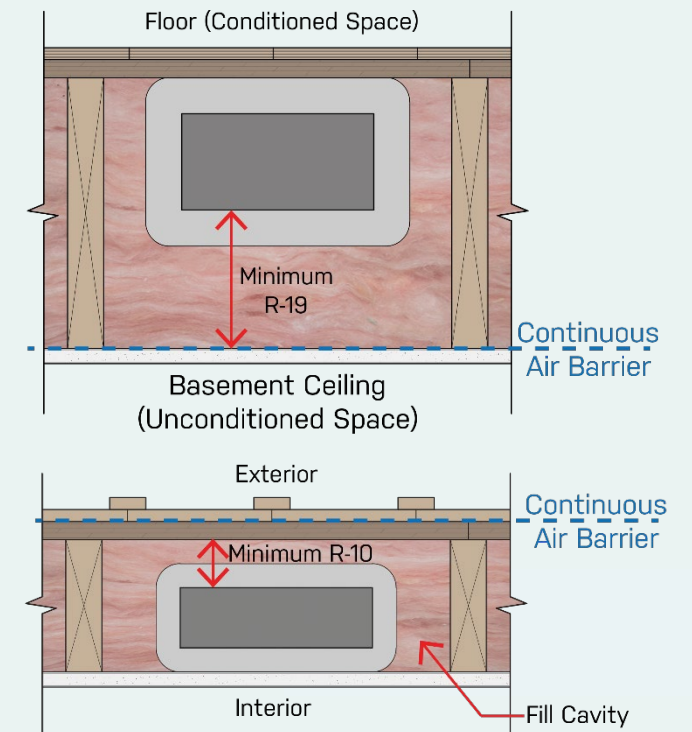
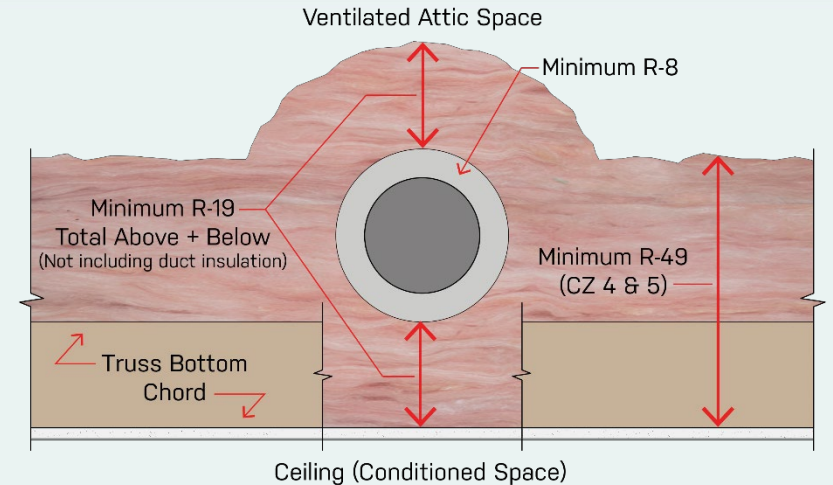

Duct Testing & Leakage

- R403.3.5 Duct Testing
 - Duct test requirements unchanged: 25 Pa pressure test
 - Ducts serving non-integral ventilation systems (HRV/ERVs) exempted from testing
- R403.3.6 Duct Leakage
 - 4.0cfm/100sf floor area with air handler, 3.0 cfm without
 - **NEW REQUIREMENT:** 8.0 cfm/100sf floor area for ducts entirely within thermal envelope.



**DUCT TESTING NOW REQUIRED
REGARDLESS OF LOCATION**



- R403.3.6 Duct Leakage

- HVAC duct systems serving 1,500 sf or less if ducts not completely within thermal envelope
- HVAC duct systems serving 750sf or less if ducts completely within thermal envelope
 - 60cfm or less



Hot water pipe insulation

This section states insulation for the following service hot water piping shall meet minimum thermal resistance of R-3:

- Piping $\frac{3}{4}$ " and larger in nominal diameter ***located inside conditioned space (Added in 2021 IECC)***
- Piping serving more than one dwelling unit
- Piping located outside the conditioned space
- Piping from the water heater to a distribution manifold
- Piping located under a floor slab
- Buried piping
- Supply and return piping in ***circulation and recirculation systems other than cold water return demand recirculation systems (Added in 2021 IECC)***

Ventilation Fan Efficacy

Fan Location	Min. Airflow Rate	Min. Efficacy [CFM/W]	Fan Location	Min. Airflow Rate	Min. Efficacy [CFM/W]
2018 IECC			2021 IECC		
HRV/ ERV	Any	1.2	HRV/ ERV	Any	1.2
In-Line	Any	2.8	In-Line	Any	3.8
Bath/Utility	<90	1.4	Other	<90	2.8
Bath/Utility	≥90	2.8	Other	≥90	3.5
Range Hood	Any	2.8	Integrated with HVAC	Any	1.2

Grouped all common fans as “Other” and increased efficacy (bath, range, utility)
 In-Line Fan efficacy reduced
 Added supply-only ventilation fans as “Integrated with HVAC”

Ventilation Fan Efficacy

Fan efficacy must be on fan label or in the product documentation

Can find fan information at HVI website:

<https://www.hvi.org/hvi-certified-products-directory/section-i-complete-product-listing/>

Product Category	Brand Name	Model	SP	Rated CFM	Rated Watts	Efficacy (CFM/W)	2021 IECC
Bathroom Exhaust Fans	Homewerks Worldwide	7140-50-G3	0.1	50	17	2.9	YES
Bathroom Exhaust Fans	Homewerks Worldwide	7140-50-G3	0.1	80	28	2.9	YES
Bathroom Exhaust Fans	Hampton Bay	1000750751	0.1	70	50	1.4	NO
Bathroom Exhaust Fans	Hampton Bay	1000750752	0.1	110	31.8	3.5	YES
Bathroom Exhaust Fans	Delta	100F	0.1	100	12.6	7.9	YES
Bathroom Exhaust Fans	Uberhaus	30395000	0.1	70	24.7	2.8	YES
Bathroom Exhaust Fans	Uberhaus	30395001	0.1	90	56	1.6	NO
Bathroom Exhaust Fans	Utilitech	553457	0.1	70	13.2	5.3	YES



Ventilation Testing



Installed fans must now be **TESTED** to verify performance
Avoids issue of installing rated fan, but duct length and bends
reduce flow rate.

- Exception for kitchen range hoods w/ 6" duct & at most 1 bend



<https://energyconservatory.com/applications/air-flow-devices/>

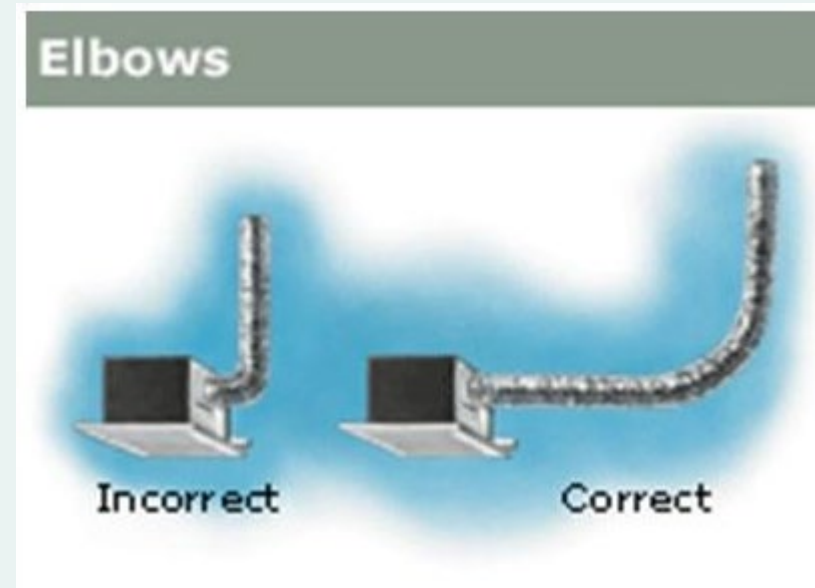

<https://basc.pnnl.gov/resource-guides/bathroom-exhaust-fans#edit-group-description>

Minimum mechanical ventilation rate can be reduced by 30% if:



- Whole-house ventilation system is a balanced ventilation system

AND

- Ducted system supplies ventilation directly to each bedroom and to one or more of the following:
 - Living room
 - Dining room
 - Kitchen

HVAC Load and Sizing Calculation

All HVAC systems required to have load calculation per ACCA Manual J
All Systems required to be sized per ACCA Manual S

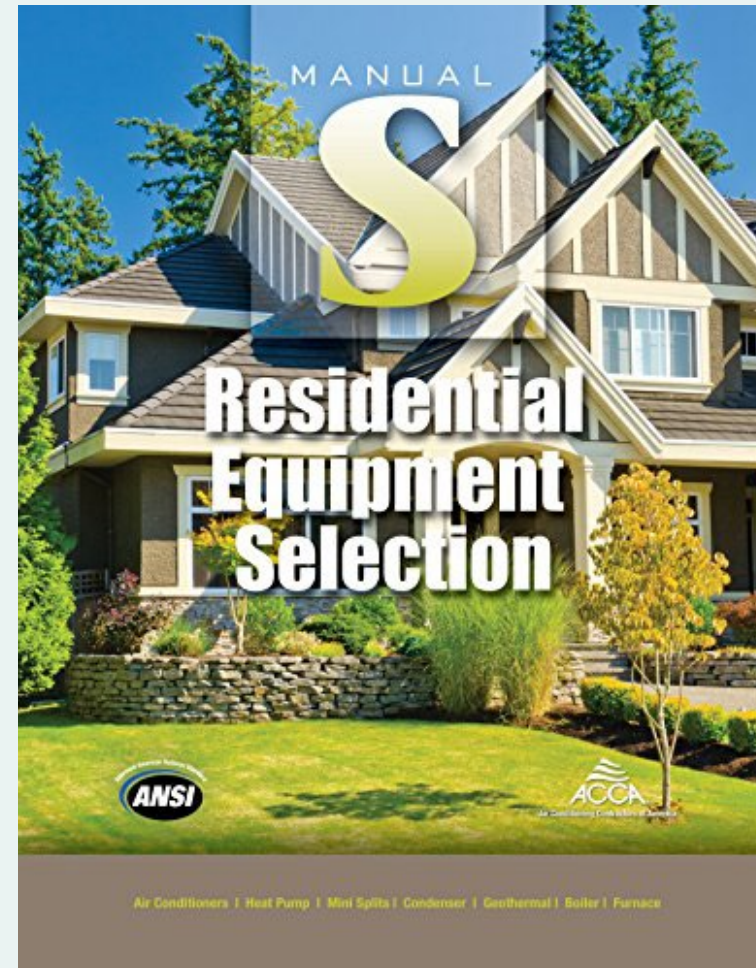
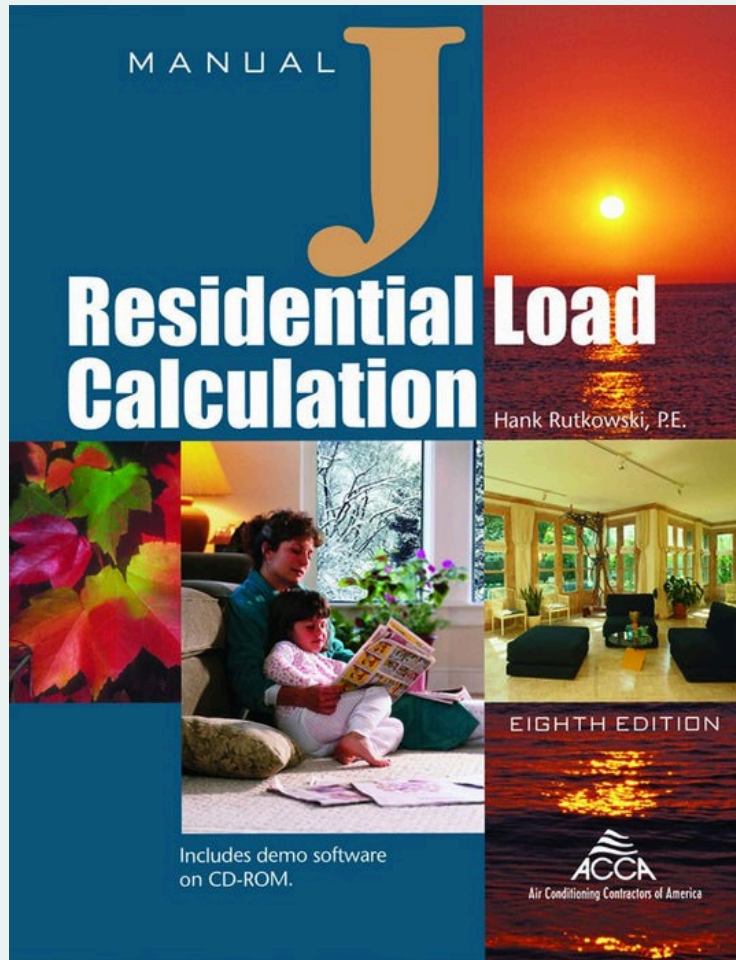

HVAC Load and Sizing Calculation

Manual J determines building loads, and should be conducted for all new construction and renovation projects

Manual S uses Manual J results to determine properly sized HVAC system

Manual D sizes duct systems. Required by International Residential Code (Section M1601.1).



Image sources: Air Conditioning Contractors of America

Note: Be sure to use approved software or speed sheets!

- 2018 IECC: 90%+ of permanent lighting shall be high-efficacy
- **2021 IECC: 100%** of permanent lighting shall be high efficacy

Does not impact plug-in lighting sources like floor and desk lamps



Image source: GE Lighting

Interior Lighting Controls

New requirement to 2021 IECC – Residential Lighting Controls

- **PERMANENTLY INSTALLED FIXTURES** shall have dimmer, occupant sensor control, or other control installed or built into fixture.
- *Exceptions include*
 - *Bathrooms*
 - *Hallways*
 - *Exterior lighting fixtures**
 - *Lighting for safety or security*

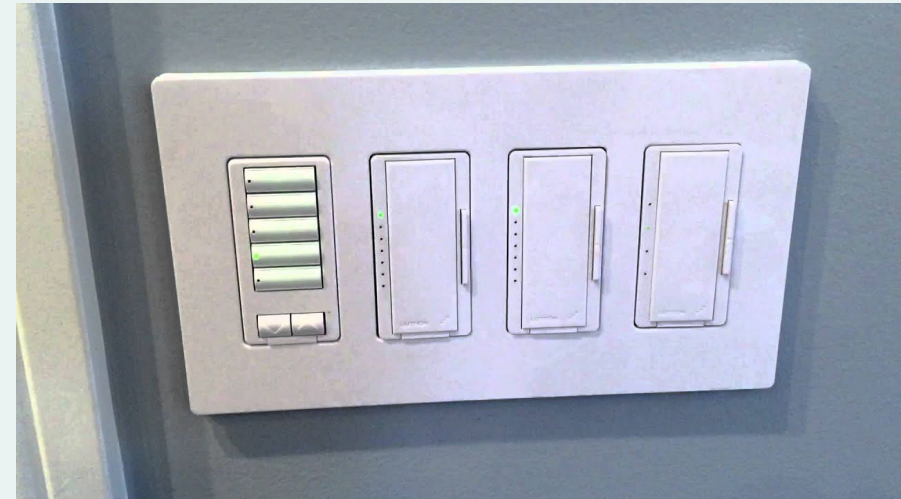

Image source: <https://manuals.plus/lutron/wireless-lighting-control-manual#axzz7Xos3cbjA>



NEW!

New to 2021 IECC – Exterior Lighting Controls

- **PERMANENTLY INSTALLED** outdoor lighting >30 W in total power required to turn off with adequate daylight
- Can be photocell or time clock
- Override permitted up to 24hrs
 - Must then return to automatic operation



Image source: cnet.com

PHIUS Compliance Option

Documentation to be provided prior to issuance of *building permit*

- List of compliance features
- PHIUS precertification letter

Documentation to be provided prior to issuance of *certificate of occupancy*

- PHIUS 2021 (or later) project certificate



The Passive House Institute US Awards

The Designation of

PHIUS+ 2015 CERTIFIED PROJECT

No. 1421
577 W. 161st St
577 W. 161 St
New York, NY 10032

• INTERIOR CONDITIONED FLOOR AREA	11,757	ft ²
• ANNUAL HEATING DEMAND	2.79	kBTU/ft ² ·yr
• ANNUAL COOLING DEMAND	5.35	kBTU/ft ² ·yr
• PEAK HEATING LOAD	3.72	BTU/ft ² ·hr
• PEAK COOLING LOAD	2.82	BTU/ft ² ·hr
• AIR-TIGHTNESS TEST RESULTS	0.06	CFM50/ft ²
• SOURCE ENERGY	6,942 5,392 (PV)	kWh/person·yr
• SITE ENERGY USE INDEX (EUI)	567	kBTU/ft ² ·yr

Rohan Development LLC
PROJECT OWNER
February 10, 2021
DATE
Carmel Pratt
CPHC®
PM Architecture PC
ARCHITECT
Technocraft Inc
CONSTRUCTION
Jordan Dentz
ON-SITE VERIFICATION

Karm S.
Executive Director

PHIUS
Passive House Institute US

Image source: pmarchitecture.com

Added clarification for change in space conditioning

- Examples: Converting garage to conditioned room, conditioning attic, etc...
 - Performance Path: If proposed design is 110% of reference design, addition is compliant
 - Performance Path: If Addition + Original Building energy cost is less than Original Building alone
 - UA Trade-off: Where UA of building + addition is less than UA of original building

Removed restriction to exception for extending existing ducts to addition

- No longer must be <40ft in unconditioned space to qualify for exception

Like R502 Additions, the duct requirements have been relaxed

- **2018 IECC:** New HVAC ducts shall comply with R403,
 - If length of alteration <40ft in unconditioned space, don't need to test for leakage.
- **2021 IECC: Altered HVAC ducts shall comply with R403,**
 - If alteration is **extension of existing ducts to an addition**, exempt from R403

Change of Occupancy or Use

2018 IECC R505.1: **Any space** changing occupancy class that **increases demand** for energy shall comply with full energy code

2018 IECC R505.2: Any space converted to a dwelling unit...from another use or occupancy shall comply with this code

2021 IECC R505.1.1: Any unconditioned or low-energy space altered to become conditioned space shall be brought into full compliance with this code.



Image Source: <https://www.feldcochicago.com/garage-living-space/>

Performance

2018 IECC R505.1: **Any space** changing occupancy class that **increases demand** for energy shall comply with full energy code

2018 IECC R505.2: Any space converted to a dwelling unit...from another use or occupancy shall comply with this code

2021 IECC R505.1.1: Any unconditioned or low-energy space altered to become conditioned space shall comply with R502-Additions



Image Source: <https://www.feldcochicago.com/garage-living-space/>

Resources

ashrae-meteo.info/v2.0/ (local design conditions)

Codes.iccsafe.org (free view-only code books)

www.ashrae.org/technical-resources/standards-and-guidelines/read-only-versions-of-ashrae-standards (free view-only ASHRAE Standards)



Questions?

energycode@illinois.edu

800-214-7954